



AGENDA FOR THE PLANNING COMMITTEE

Members of Planning Committee are summoned to a meeting, which will be held in the Council Chamber, Town Hall, Upper Street, N1 2UD on **8 September 2015 at 7.30 pm.**

John Lynch
Head of Democratic Services

Enquiries to : Zoe Crane
Tel : 020 7527 3044
E-mail : democracy@islington.gov.uk
Despatched : 28 August 2015

Welcome:

Members of the public are welcome to attend this meeting.

Consideration of Planning Applications – This is a formal agenda where decisions are taken on planning applications submitted to the Council. Public speaking rights on these items are limited to those wishing to comment on specific applications. **If you wish to speak at the meeting please register by calling the Planning Department on 020 7527 2278 or emailing enquiriesplanning@islington.gov.uk.**

Committee Membership

Councillor Khan (Chair)
Councillor Fletcher (Vice-Chair)
Councillor Klute (Vice-Chair)
Councillor Chowdhury
Councillor Convery
Councillor Gantly
Councillor Ismail
Councillor Nicholls
Councillor Poyser
Councillor Spall

Wards

- Bunhill;
- St George's;
- St Peter's;
- Barnsbury;
- Caledonian;
- Highbury East;
- Holloway;
- Junction;
- Hillrise;
- Hillrise;

Substitute Members

Councillor Diner
Councillor Kay
Councillor A Perry
Councillor Picknell
Councillor Wayne
- Canonbury;
- Mildmay;
- St Peter's;
- St Mary's;
- Canonbury;

Quorum: 3 councillors



| A. Formal Matters | Page |
|---------------------------------------|-------------|
| 1. Introductions | |
| 2. Apologies for Absence | |
| 3. Declarations of Substitute Members | |
| 4. Declarations of Interest | |

If you have a **Disclosable Pecuniary Interest*** in an item of business:

- if it is not yet on the council's register, you **must** declare both the existence and details of it at the start of the meeting or when it becomes apparent;
- you may **choose** to declare a Disclosable Pecuniary Interest that is already in the register in the interests of openness and transparency.

In both the above cases, you **must** leave the room without participating in discussion of the item.

If you have a **personal** interest in an item of business **and** you intend to speak or vote on the item you **must** declare both the existence and details of it at the start of the meeting or when it becomes apparent but you **may** participate in the discussion and vote on the item.

***(a) Employment, etc** - Any employment, office, trade, profession or vocation carried on for profit or gain.

(b) Sponsorship - Any payment or other financial benefit in respect of your expenses in carrying out duties as a member, or of your election; including from a trade union.

(c) Contracts - Any current contract for goods, services or works, between you or your partner (or a body in which one of you has a beneficial interest) and the council.

(d) Land - Any beneficial interest in land which is within the council's area.

(e) Licences- Any licence to occupy land in the council's area for a month or longer.

(f) Corporate tenancies - Any tenancy between the council and a body in which you or your partner have a beneficial interest.

(g) Securities - Any beneficial interest in securities of a body which has a place of business or land in the council's area, if the total nominal value of the securities exceeds £25,000 or one hundredth of the total issued share capital of that body or of any one class of its issued share capital.

This applies to **all** members present at the meeting.

| | |
|---|-------------|
| 5. Order of Business | |
| 6. Minutes of Previous Meeting | 1 - 4 |
| B. Consideration of Planning Application | Page |
| 1. Redbrick Estate including Vickery Court, Bartholomew Court, Steadman Court, Community Centre at 163 Old Street, 169-173 Old Street, Bath Street Health | 5 - 88 |

Centre, Islington, London, EC1V

C. Urgent non-exempt items (if any)

Any non-exempt items which the Chair agrees should be considered urgent by reason of special circumstances. The reasons for urgency will be agreed by the Chair and recorded in the minutes.

Date of Next Meeting: Planning Committee, 13 October 2015

Please note all committee agendas, reports and minutes are available on the council's website:

www.democracy.islington.gov.uk

PROCEDURES FOR PLANNING COMMITTEE

Planning Committee Membership

The Planning Committee consists of ten locally elected members of the council who will decide on the applications for planning permission.

Order of Agenda

The Chair of the Planning Committee has discretion to bring forward items, or vary the order of the agenda, where there is a lot of public interest.

Consideration of the Application

After hearing from council officers about the main issues of the proposal and any information additional to the written report, the Chair will invite those objectors who have registered to speak for up to three minutes on any point relevant to the application. If more than one objector is present for any application then the Chair may request that a spokesperson should speak on behalf of all the objectors. The spokesperson should be selected before the meeting begins. The applicant will then be invited to address the meeting also for three minutes. These arrangements may be varied at the Chair's discretion.

Members of the Planning Committee will then discuss and vote to decide the application. The drawings forming the application are available for inspection by members during the discussion.

Please note that the Planning Committee will not be in a position to consider any additional material (e.g. further letters, plans, diagrams etc.) presented on that evening. Should you wish to provide any such information, please send this to the case officer a minimum of 24 hours before the meeting. If you submitted an objection but now feel that revisions or clarifications have addressed your earlier concerns, please write to inform us as soon as possible.

What Are Relevant Planning Objections?

The Planning Committee is required to decide on planning applications in accordance with the policies in the Development Plan unless there are compelling other reasons. The officer's report to the Planning Committee will refer to the relevant policies and evaluate the application against these policies. Loss of light, openness or privacy, disturbance to neighbouring properties from proposed intrusive uses, over development or the impact of proposed development in terms of size, scale, design or character on other buildings in the area, are relevant grounds for objection. Loss of property value, disturbance during building works and competition with existing uses are not. Loss of view is not a relevant ground for objection, however an unacceptable increase in sense of enclosure is.

For further information on how the Planning Committee operates and how to put your views to the Planning Committee please call Zoe Crane on 020 7527 3044. If you wish to speak at the meeting please register by calling the Planning Department on 020 7527 2278 or emailing enquiriesplanning@islington.gov.uk.

London Borough of Islington

Planning Committee - 7 July 2015

Minutes of the meeting of the Planning Committee held at Council Chamber - Town Hall on 7 July 2015 at 7.30 pm.

Present: **Councillors:** Kat Fletcher (Vice-Chair), Martin Klute (Vice-Chair),
Paul Convery, Osh Gantly, Tim Nicholls and David
Poyser

Councillor Martin Klute in the Chair

119 **INTRODUCTIONS (Item A1)**

Councillor Klute welcomed everyone to the meeting. Members of the Committee and officers introduced themselves and the Chair outlined the procedures for the meeting.

120 **APOLOGIES FOR ABSENCE (Item A2)**

Apologies were received from Councillors Chowdhury, Khan and Spall.

121 **DECLARATIONS OF SUBSTITUTE MEMBERS (Item A3)**

There were no substitute members.

122 **DECLARATIONS OF INTEREST (Item A4)**

There were no declarations of interest.

123 **ORDER OF BUSINESS (Item A5)**

The order of business would be as per the agenda.

124 **MINUTES OF PREVIOUS MEETING (Item A6)**

RESOLVED:

That the minutes of the meeting held on 9 June 2015 be confirmed as an accurate record of proceedings and the Chair be authorised to sign them.

125 **46 ESSEX ROAD AND 160-162 PACKINGTON STREET, LONDON, N1 (Item B1)**

Part change of use and part redevelopment of 46 Essex Road, 160 Packington Street and 162 Packington Street and land to the rear fronting onto Queens Head Street to provide a total of 2350sqm B1 office space and the creation of one additional residential (C3) flat (in addition to 2 existing units) to create a total of 3 (2x3 bed and 1x2 bed). The proposals include the erection of a four storey (including basement) B1 office building fronting onto Queens Head Street and roof top additions to 162 Packington Street including alterations and improvements to the façade of the existing buildings.

(Planning application number: P2015/0971/FUL)

In the discussion the following points were made:

- The planning officer stated that the reference to 13 weeks in the second paragraph on page 46 of the officer's report should be removed as it was no longer applicable as the applicant had entered into a planning performance agreement for this scheme.

Planning Committee - 7 July 2015

- The planning officer confirmed that affordable workspace was defined by reason of its size or reduced rates. In this case, it was size.
- There were 85sqm of affordable workspace and this meant approximately 10 people could use the space.
- Affordable workspace made up 3.6% of the workspace rather than a minimum of 5% which was specified in policy. At 3.6% of floorspace and 85sqm, the unit would have been considered a small or micro enterprise unit.
- Given that a 5% of workspace was required as per policy DM5.4D, the policy also sought that the rent for the affordable workspace unit be secured as peppercorn rate for at least 10 years to a council-approved Workspace Provider.
- The planning officer confirmed that amenity in the proposed dwelling was considered acceptable.
- The reconsultation did not include the revised entrance for the affordable workspace as with approximately 10 users, this was not considered a material change to the scheme. The main entrance was on Essex Road.
- The yard had been designated as commercial land and had previously been the servicing area for Merchants Hall.
- Concern was raised about the management of cycles.
- Concern was raised that policy required large single occupier units to be designed so they could be divided into the smaller units in the future and the proposed development could only be divided by floor. The applicant stated that the building was a locally listed building and the layout of the existing building lent itself to one large office space. The office space would initially be marketed as one unit but would be subdivided in the future if necessary.
- A shared surface was not supported by officers as it could impact upon road safety and the amenity of neighbouring residents.
- Policy supported the use remaining commercial.

Councillor Klute proposed that Condition 7 be amended to require the floorplan to be amended to provide 5% affordable workspace. This was seconded by Councillor Poyser and carried.

Councillor Nicholls proposed a motion that the amended affordable workspace be secured in terms of management and lease, as per policy DM5.4, with further advice to be taken from the Policy Team. This was seconded by Councillor Klute and carried.

[Post meeting discussion and detail: Officers had discussed this internally and considered that given the amended business unit would be approximately 117.5sqm in size (at 5% of the scheme's floorspace) this would no longer constitute a 'small or micro enterprise' and must be assessed against Part D of the policy. If the applicant intended to retain this floor area as a single unit, then the applicant would need to agree to lease the workspace at a peppercorn rent for at least 10 years to a council-approved Workspace Provider. This must be secured as part of the S106 agreement. However, in the event that the applicant identified the 117.5sqm floorspace as divided into two (or more) units, these would be classified as either micro (10-50sqm) or small (50 to 90sqm) workspaces and would be considered as 'affordable' by virtue of their size.]

Councillor Convery proposed a motion that officer check the policy requirements in relation to management and lease issues and secure by condition or S106 as appropriate in consultation with the chair. This was seconded by Councillor Klute and carried.

Councillor Klute proposed a motion to require the use of solid bricks. This was seconded by Councillor Convery and carried.

Councillor Convery proposed a motion to condition that the brickwork be Flemish Bond. This was seconded by Councillor Klute and carried.

Councillor Klute proposed that the management of cycles should be included in the travel plan. This was seconded by Councillor Nicholls and carried.

RESOLVED:

That planning permission be granted subject to the conditions and informatives set out in Appendix 1 of the case officer's report with the amendments outlined above, the wording of which was delegated to officers in consultation with the chair, plus the prior completion of a Deed of Planning Obligation made under Section 106 of the Town and Country Planning Act 1990 securing the heads of terms as set out in Appendix 1 of the case officer's report as amended above.

126

**CHARTER HOUSE, 2 FARRINGDON ROAD AND UNITS 501 AND 502 LONDON
CENTRAL MARKETS GATE 30, 45 CHARTERHOUSE STREET, LONDON, EC1 (Item
B2)**

Erection of an 11-storey building comprising 3,054 square metres (GIA) of Class A1 (retail) and 22,073 (GIA) square metres of Class B1 (office), along with ancillary facilities including the provision of basement level servicing.

(Planning application number: P2015/0053/FUL)

In the discussion the following points were made:

- The applicant stated that there was flexibility within the S106 agreement regarding a memorial plaque. The planning officer highlighted that this was being secured within the S106 agreement as per the exact clauses within the previously signed agreement.
- The S106 stated that the memorial plaque would not exceed £10,000.
- Cycle parking for visitors should be provided outside of the building.

Councillor Klute proposed a motion to amend Condition 13 to include cycle parking for visitors outside of the building. This was seconded by Councillor Nicholls and carried.

Councillor Klute proposed a motion to add an informative to recommend that the applicants did what they could to locate and replace the memorial plaque. This was seconded by Councillor Fletcher and carried.

RESOLVED:

That planning permission be granted subject to the conditions and informatives set out in Appendix 1 of the case officer's report with the amendments outlined above, the wording of which was delegated to officers, plus the prior completion of a Deed of Planning Obligation made under Section 106 of the Town and Country Planning Act 1990 securing the heads of terms as set out in Appendix 1 of the case officer's report and subject to any direction by the Mayor of London to refuse the application or for it to be called in for determination by the Mayor of London.

WORDING DELEGATED TO OFFICERS

This wording has been provided by officers following the meeting and is included here for completeness.

MINUTE 126

**CHARTER HOUSE, 2 FARRINGDON ROAD AND UNITS 501 AND 502 LONDON
CENTRAL GATE 30, 45 CHARTERHOUSE STREET, LONDON, EC1 (Item B2)**

AMENDED CONDITION 13: The bicycle storage area, which shall provide for no less than 327 bicycle spaces and shower and changing facilities, as well as visitor cycle parking where feasible at ground level outside the building, shall be provided in accordance with the hereby approved plans prior to the first occupation of the development and maintained as such thereafter.

REASON: To ensure adequate cycle parking and associated facilities are available and easily accessible on site and to promote sustainable modes of transport.

The meeting ended at 9.10 pm

CHAIR

PLANNING COMMITTEE REPORT

Development Management Service
 Planning and Development Division
 Environment and Regeneration Department
 PO Box 333
 222 Upper Street
 LONDON N1 1YA

| PLANNING COMMITTEE | | AGENDA ITEM NO: B1 |
|--------------------------|---|--------------------|
| Date: | 8 September 2015 | |
| Application number | P2015/0709/FUL | |
| Application type | Full Planning Application | |
| Ward | Bunhill Ward | |
| Listed building | No Listing. Opposite Grade I St Luke's Church to the west. | |
| Conservation area | None. St Luke's Conservation Area to west, north and south west. | |
| Development Plan Context | Bunhill and Clerkenwell Core Strategy Key Area Finsbury Local Plan Area Site Allocation BC18 (Redbrick Estate) Central Activities Zone Site of Importance for Nature Conservation (SINC) BC3 Old Street Policy Designated Open Space (Old Street Verge) Local Cycle Route (Old Street) Major Cycle Route (Bath Street) | |
| Licensing Implications | None. | |
| Site Address | Redbrick Estate including Vickery Court, Bartholomew Court, Steadman Court, Community Centre at 163 Old Street, 169 - 173 Old Street, Bath Street Health Centre, Islington, London, EC1V. | |
| Proposal | Demolition of Vibast Community Centre, 169-173 Old Street and Health Centre, partial demolition of garages to west of Bath Street, the construction of 55 new homes (comprising 16 x 1 bed units, 25 x 2 bed units and 7 x 3x bed), a community centre (D1 use), two flexible A1/A2 use units across three buildings, consisting of the erection of a part single, four and nine storey building at the junction of Old Street and Bath Street to provide a community centre and A1/A2 unit with residential above, a part two and three storey building at the Junction of Old Street and St Luke's Close to provide an A1/A2 unit and residential units and a part single and four storey residential | |

| | |
|--|---|
| | building fronting Bath Street, alterations to the garages fronting Bath Street, the provision of a new amenity space to the east of Steadman Court and public realm improvement works across the site, inclusive of hard and soft landscaping, cycle parking, alterations to entrances and alterations to boundary treatment. |
|--|---|

| | |
|--------------|---|
| Case Officer | Nathaniel Baker |
| Applicant | Teresa Santucci - New Build and Regeneration Team, London Borough of Islington. |
| Agent | Riette Oosthuizen - HTA Design LLP |

1 RECOMMENDATION

The Committee is asked to resolve to **GRANT** planning permission:

1. subject to the conditions set out in Appendix 1; and
2. conditional upon the prior completion of a Directors' Agreement securing the heads of terms as set out in Appendix 1.

2 SITE PLAN (SITE OUTLINED IN BLACK)



PHOTOS OF SITE



Photograph 1: Aerial View of Site



Photograph 2: View of Redbrick Estate from Old Street



Photograph 3: View into estate from Bath Street

SUMMARY

- 4.1 The planning application proposes the demolition of a community centre, a two storey building at 169-173 Old Street and a health centre to facilitate the construction of three residential blocks to provide 55 new dwellings, a community centre, two flexible retail/professional services units, a new amenity space and extensive landscaping works.
- 4.2 The scheme delivers good quality housing including a high proportion of affordable housing (70.9% by unit and 76.5% by habitable rooms, all social rent tenure) and accessible accommodation to address housing needs within the borough. The tenure mix proposed is supported by a financial viability assessment which has factored in an element of public subsidy.
- 4.3 The proposal would re-provide a community centre and two flexible retail/professional service units on site and replace the social infrastructure and commercial services lost at the site while the loss of the vacant health centre is justified.
- 4.4 The proposal would introduce three buildings across the estate, providing development of a high quality design with an appropriate scale, which successfully references the established and emerging context of the site and surrounding area. The consistent material palette across all of the proposed buildings, the boundary treatment and the alterations to the existing blocks would also ensure a coherency across the estate. While 21 trees would be removed, 70 would be planted.
- 4.5 The landscaping proposals would introduce a greater quantum of amenity space and provide a new area of open space, addressing a need for high quality open space within the borough. The landscaping scheme would provide a high quality environment that would improve the legibility of the estate.
- 4.6 Residents' concerns predominantly relate to issues surrounding anti-social behaviour and crime across the estate. The landscaping and design proposals would provide an appropriate design response to address the safety, security and anti-social behaviour concerns at the site. The applicants have proposed that two gates facing onto Old Street are locked at night. However, this would be contrary to policy as it would reduce the permeability and legibility of the estate. A condition requiring these gates to remain open at all times has therefore been recommended (Condition 8).
- 4.7 There are identified effects and losses of daylight receipt to neighbouring properties as a result of the development. Following a critical assessment of these losses it is considered that the vast majority are acceptable losses in the context of the urban location. The individual window impacted to a great extent is not considered to justify the refusal of the application in the context of the balance of various planning considerations and the significant benefits within the proposal including the increase in useable amenity space and new social housing.
- 4.8 The proposal would connect to the Bunhill Energy Network and the sustainability measures proposed are in accordance with policy and would ensure a sustainable and green development that would minimise carbon emissions in the future. A carbon off-set contribution is secured in the Directors' Agreement for this development to off-set emissions to 'zero'. The proposed SUDS strategy is acceptable.
- 4.9 Car parking at the site would be significantly reduced, from 104 spaces to 40 with sufficient accessible parking spaces provided. Cycle parking accords with policy requirements and would re-provide lost cycle parking spaces across the site.
- 4.10 The significant benefits with this proposal, in particular the increase in useable amenity space and new housing are considered to significantly outweigh any potential negative impacts. As

such, the proposal is considered to be acceptable and is recommended for approval subject to conditions and the completion of a Directors' Agreement to secure the necessary mitigation.

5 SITE AND SURROUNDING

- 5.1 The application site is located on the north side of Old Street and is bounded by Bath Street to the east, St. Luke's Close to the west with Mitchell Street and Cope House forming the northern boundary to the site. The site is made up of 112 residential units, two community uses, a vacant health centre, a dentist and three commercial units.
- 5.2 The site comprises of two centrally located linked four storey residential blocks laid out with an almost north-south and east-west footprint, a four storey residential block with a 'T' shaped layout in the north west corner of the site, a two storey car park backing onto Bath Street and adjoining a four storey residential block located outside of the site (Cope House), a single storey health centre, a mixed use two storey building at the south east corner of the site comprising A2, D1 and Sui Generis uses and a single storey community centre on the south west corner of the site. The ground floor units have direct access off the pedestrian routes through the estate whilst the upper floors have a shared core with deck access.
- 5.3 There are seven defined areas of green space spread across the site with some of these bound by high fences. Five of these areas are designated as Sites of Importance for Nature Conservation (SINC). Additionally there are a number of mature trees, with two raised planters beyond the south eastern corner of the site that form Designated Open Space.
- 5.4 The estate has a number of pedestrian routes running through it from both east to west and north to south, with a vehicular access leading to parking areas at both the eastern and western sides of the estate. To the east of the site is the 'Promenade of Light' a tree lined, illuminated pedestrian promenade that runs from Old Street Roundabout to Bath Street.
- 5.5 To the east of the site is a nine storey building with commercial uses at ground floor level and residential above, the buildings to the south are between two and seven storeys in height in a mix of uses and beyond the site to the north are a number of three, four and five storey buildings in mixed uses, St. Luke's Primary School and three residential tower blocks between 17 and 22 storeys in height.
- 5.6 St. Luke's Conservation Area wraps around the north and west boundaries of the site with St. Luke's Church immediately to the west of the site which is Grade I Listed and a designated Local Landmark.

6 PROPOSAL (IN DETAIL)

- 6.1 The proposal comprises of the demolition of the Vibast Community Centre, 169-173 Old Street and the health centre (D1 use class), the partial demolition of the garage building to the east of the site and the construction of 55 new homes (16 x 1 bed units, 25 x 2 bed units and 7 x 3x bed), a community centre (D1 use class) and two flexible A1/A2 units across three infill sites, alterations to the garages, public realm improvement works, the provision of amenity space and alterations to boundary treatment.
- 6.2 The development proposes a housing split of 76.5% by habitable rooms / 70.9% by unit of affordable housing (social rent) and 23.5% by habitable rooms / 29.1% by units of private housing. It would provide 8 wheelchair accessible units, representing 9.83% of habitable rooms and 10.9% by units.

6.3 The proposal for each infill development and the landscaping is detailed below:



- 6.4 **Block A:** Proposes the erection of a part nine, part four and part single storey block over basement. The taller element would be located on the south east corner of the site between Bath Street and Old Street with a four storey projection fronting onto Old Street. The single storey element would project from the west flank of this block.
- 6.5 It would provide a community centre (D1 use class) measuring 379.95 square metres within a projecting single storey element and a flexible retail/professional services unit (A1/A2 use class) measuring 164.4 square metres within the base of the main block with 35 residential units above comprising 13 x 1 bed / 2 person units, 4 x 2 bed / 3 person units and 18 x 2 bed / 4 person units. The residential units would be a mix of private and social housing.
- 6.6 **Block B:** Proposes the erection of a part two and part three storey block over basement in the south west corner of the site. The Old Street frontage would incorporate a glazed shopfront with the upper floors overhanging this.
- 6.7 It would provide a flexible retail/professional services unit (A1/A2 use class) measuring 189.9 square metres at ground floor level with nine residential units to the rear and above comprising 1 x 1 bed / 2 person unit, 2 x 2 bed / 3 person units, 1 x 2 bed / 4 person units, 3 x 3 bed / 5 person units and 2 x 3 bed / 6 person units. All 9 residential units would be social housing.
- 6.8 **Block C:** Proposes the partial demolition of the two storey garages and the erection of a four storey residential block and alterations to the elevations of the garage block.
- 6.9 It would provide 11 residential units comprising 2 x 1 bed / 2 person unit, 6 x 2 bed / 4 person units and 3 x 3 bed / 5 person units. All 11 residential units would be social housing.
- 6.10 All of the proposed blocks would be provided with green roofs and solar panels.
- 6.11 **Existing Residential Blocks:** Secure entrances with fob-access would be introduced to the stairwells of the existing residential blocks.

6.12 Landscaping: The proposal includes extensive landscaping works as set out below:

- The existing vacant medical centre would be replaced with a new communal amenity space measuring 698 square metres, consisting of a raised planted area with 1.5 metre high boundary brick plinth and railings, two non-lockable 1.5 metre high gates, with boundary railings extending around the amenity space and across the pedestrian walkways;
- Repaving of hardstanding across the site, comprising of pedestrian routes, shared surfaces where there is vehicular access and parking, the delineation of defensible space to the front of ground floor residential properties, variations in hardstanding to form 'doormats' to estate entrances and introduction of informal toddler age door-step play;
- The two pedestrian entrances from Old Street would be reduced in width with over-sailing concrete lintels and laser cut gates. The applicant seeks permission for these to be locked at night;
- Over sailing concrete lintel entrance markers are proposed to the Lizard Street and Bath Street entrances to the site;
- Introduction of planters to the front of ground floor properties and railing chicanes to walkways to prevent cyclists and motorbikes travelling through the estate at speed;
- Provision of new ramped entrances to the Wildflower Meadow Garden and Wildflower Garden;
- Planting to rear boundary fencing of properties backing onto the existing open spaces, replacement of timber fencing onto pedestrian areas with brick walls at the same height incorporating a 0.3 metre high trellis above and planting to northern boundary of Wildflower Meadow (onto Mitchell Street);
- A 1.5 metre high brick plinth and metal railing boundary treatment would be added to the open space fronting St. Luke's Close;
- The existing high boundary wall onto Old Street would have pre-cast concrete lintels, textured brick panels and laser cut metal fretwork panels inserted;
- Insertion of gate leading to No. 10 Vickery Court and replacement of east and west ends of railings with 1 metre brick wall;
- The Bath Street entrance would be relocated 1 metre to the south;
- Metal gates are proposed to recessed bin stores with fob access introduced;
- A lighting strategy is proposed across the site;
- The removal of 21 trees (and three tree stumps) across the site and the planting of 70 new trees; and
- Provision of cycle and mobility scooter stores across the site.

Revision 1:

6.13 The Planning Statement was amended on 5th May 2015.

Revision 2:

- 6.14 The plans were amended on 21st May 2015 to address the Inclusive Design Officer's comments and omit a substation.

Revision 3:

- 6.15 An addendum to the Daylight, Sunlight and Overshadowing report was received on 27th May 2015. The plans were amended on 28th May 2015 to add a first floor window to the east elevation of Block B.

Revision 4:

- 6.16 The plans were amended on 15th July 2015 to relocate the sub-station to within the garages, with four parking spaces lost and two doors added to the Bath Street elevation of the garages.

7

RELEVANT HISTORY:

PLANNING APPLICATIONS:

- 7.1 **P2014/0203/S73** - Section 73 application to vary Condition 2 (Duration of which artwork can remain in situ) of planning permission P111249, dated 05 August 2011 for the existing mural to be displayed for an additional 2 years – Granted Conditional Permission (25/04/2014)
- 7.2 **P111249** – Application to vary the wording of condition 3 (duration of which artwork can remain in situ) of planning permission ref: P101364, dated 22/09/11 for the: 'Installation of a memorial comprising an artistic mural' - Granted Conditional Permission (05/08/2011)
- 7.3 **P101364** – Installation of a memorial comprising an artistic mural – Granted Conditional Permission (03/09/2010)
- 7.4 **P101337** – Change of use of the caretaker's store room within the community centre to a tenant management office – Granted Conditional Permission (27/09/2010)
- 7.5 **P100298** – Proposed Installation of thermal Solar PV Panels on flat roof of Bartholomew Court – Granted Conditional Permission (16/04/2010)
- 7.6 **P100312** – Proposed Installation of thermal Solar PV Panels on flat roof of Steadman Court – Granted Conditional Permission (12/04/2010)
- 7.7 **P061092** – Renovation and change of use of part of the ground floor and the whole of the basement to include disabled lift access, stairs and a ventilation system. Change of use from use Class A2 (financial and professional services) to use Class D1 (youth/music teaching centre) at 173B Old Street – Granted Conditional Permission (01/08/2006)
- 7.8 **P041446** – Replacement of windows with UPVC double glazing and installation of mechanical extracts for kitchens and bathrooms (Bartholomew Court, Steadman Court, Old Street, Vickery Court and Mitchell Street) – Granted Conditional Permission (13/08/2004)

69-85 Old Street:

- 7.9 **P2015/1163/FUL** – Change of use of part of ground and basement floors from Use Class A2 to Use Class D1 including alterations to external ground floor facades on Old Street and Central Street elevations – Granted Conditional Permission (29/06/2015).

148 Old Street (Opposite the site):

- 7.10 **P2014/4519/FUL** – Re-cladding of elevations to Old Street, Bunhill Row and Banner Street, 6th floor extension to Old Street and Bunhill Row, 7th and 8th floor extensions to Old Street to provide additional office floorspace (Use Class B1), creation of new building entrance via Bunhill Row, change of use of the ground floor fronting Old Street to provide flexible retail/restaurant (Use Class A1/A3) units, and associated works – Resolution to Grant Permission at Planning Committee 24/03/2015

PRE-APPLICATION ADVICE:

- 7.11 **Q2014/3274/MJR** – The proposal has been subject to ongoing pre-application discussions. The key points which required further consideration during the pre-application process were:
- Gating and security;
 - Loss of social infrastructure;
 - Landscaping; and
 - The design and height of Blocks A and B.

ENFORCEMENT

- 7.12 None relevant.

8 CONSULTATION

Public Consultation

- 8.1 Letters were sent to occupants of 799 adjoining and nearby properties at Bath Street, Tilney Court, Whitecross Street, Bunhill Row, Mitchell Street, Radnor Street, Bartholomew Square and Old Street on 17th March 2015. A number of site notices and a press advert were displayed on 19th March 2015. Following the receipt of amended plans (see Revision 4), the application was re-advertised and all neighbouring properties re-consulted on 16th July 2015. The public consultation on the application therefore expired on 6th August 2015. However it is the Council's practice to continue to consider representations made up until the date of a decision.
- 8.2 At the time of the writing of this report a total of 129 responses and two petitions had been received from the public with regard to the application. The responses consisted of 126 objections (114 in the form of a standard letter template), two petitions with 172 signatures and 152 signatures (respectively) in objection to the proposal and 3 letters of support. The issues raised can be summarised as follows (with the paragraph that provides responses to each issue indicated within brackets):

Objections:

Design/Heritage/Security:

- Residents believed that if noise and disruption from additional density was supported an estate wide gating solution would be forthcoming to ensure proper and effective security and reduce regular daily nuisance to Cope House and Steadman Court residents (para 10.44 - 10.52);
- Security gates should be provided on the entrances to the street, particularly Old Street (para 10.53 - 10.54);
- Objection to nine storey building (para 10.24);
- Objection to the provision of boundary walls and boundary planting (para 10.86 - 10.90);

- Objection to pathways (para 10.82);
- No cameras are proposed (para 10.61);
- Bartholomew Court needs better security (para 10.62);
- Concern raised regarding loss of views of St Luke's church from Bartholomew Court (para 10.34);
- The estate has problems with crime and anti-social behaviour (para 10.44 – 10.46);
- There is no lift provision to existing blocks (para 10.211);
- Low level fencing or planting should be provided to the front of houses (para 10.50 - 10.52);
- Contrary to the Finsbury Local Plan the existing estate is excellently designed and fit for purpose, with the only anti-social behaviour coming from non-residents (para 10.44 – 10.46);
- The proposed new buildings do not integrate with the existing estate buildings and detracts from St Luke's Church (para 10.63 – 10.65);
- Block A should be increased to 11 storeys in height and include all of the proposed housing (para 10.211);

Trees, Green Space and Bio-diversity:

- The proposed green space will become a semi-public park open 24 hours a day that will result in anti-social behaviour, security concerns and disturbance (para 10.59);
- The proposal would remove long established large trees and habitat for wildlife (para 10.91 – 10.98 and 10.101);
- The Vickery Court end of the estate loses a substantial amount of green space with the only un-gated open space on the site (para 10.13);
- The proposal would not extend, retain or re-provide existing green space or trees (para 10.13 and 10.95);
- The proposed lighting is detrimental to wildlife (para 10.101);
- Green walls and green roofs were originally proposed (para 10.100);

Loss of amenity:

- The outlook, space and desirability of Vickery Court will be permanently damaged (para 10.113 and 10.116);
- Objection to the loss of visual amenity from Bartholomew Court (para 10.114 and 10.115);
- Concern raised regarding disturbance from the Community Centre (para 10.121);
- Vickery Court will be overlooked (para 10.113);
- The introduction of family units with first floor terraces and parking at Block B would lead to disturbance and overlooking to residents of Vickery Court (para 10.113 and 10.116);

- The relocated community centre would lead to a greater level of footfall, as was the case at St. Luke's Community Centre, which would increase users of the site (para 10.121);
- Concern raised regarding loss of light to Steadman Court (para 10.131 – 10.133);

Transport and Highways:

- The proposal fails to address the extremely high level of pedestrian (and cyclist) traffic passing Cope House (para 10.80 – 10.82);
- Objection raised to the parking plans for the estate (para 10.192 – 10.196);
- Concern raised regarding emergency vehicle access (para 10.204);
- The garages are only available to some residents (para 10.195);
- Objection raised to the inclusion of a ramp to the green space on the south eastern side of the site, this could be replaced with a cutting (para 10.88);
- Objection to the loss of cycle parking in the south east corner of the site (para 10.200 – 10.201).

Other:

- The proposal would result in an unacceptable density on the estate with less green space per person (para 10.13 and 10.70);
- The proposal would divide the estate by shutting off access to the top floor flats (para 10.60);
- Tenure of the site should be 50% Council and 50% private (para 10.167);
- Is there sufficient infrastructure to support additional tenants including doctors surgeries and schools (para 10.212);
- The Council is not putting any grants or cross subsidy or capital into the proposal (para 10.173 – 10.175); and
- The proposal would restrict access to Cope House via mobility scooter (para 10.76).

Support:

- No objection raised to the proposal subject to re-provision of 'City Pest House' Plaque; and
- The entry phone security doors to the stairwells will make a positive difference by improving security.

Non-planning Issues:

- Concern raised regarding noise and disruption during the construction process (para 10.205 and 10.210);
- Concerns raised regarding the pre-planning consultation process with neighbours. The proposal is not representative of the feedback from residents (para 8.3 – 8.5 and 10.213);
- The proposal would block views (para 10.209);

- It is unfair to pass the cost of the entry phone doors onto residents (para 10.215);
- Residents have voted that the estate should be renamed 'Redbrick Gardens' (para 10.214); and
- Rear gardens should be increased in size (para 10.211).

Applicant's consultation

8.3 The applicant, Islington Housing Strategy and Regeneration have carried out multiple consultation exercises at the site dating back to September 2012. This has encompassed local residents, businesses and St. Luke's School, and comprised of events, questionnaires, drop-in sessions, door-to-door consultations and newsletters.

8.4 The key issues the consultation has identified are:

- Provision of much needed housing and estate wide improvements to public space;
- The provision of a new community centre;
- Concerns over loss of green space; and the provision of new green space and play provision for children;
- Safety and security issues;
- Access through the estate by non-residents; and
- Disruption during construction.

8.5 The proposed scheme has been developed throughout the consultation process, taking into account the varied responses to the consultation.

External Consultees

8.6 **Crime Prevention Officer** – There have been a high number of calls to the police in the last year (over 100) relating to anti-social behaviour (ASB) and other crimes, with almost half of the calls relating to the area around Steadman Court.

From a crime reduction perspective controlling and limiting the permeability of any site can help reduce the crime that an area experiences. The locking of the Old Street gates at night time/hours of darkness would protect the estate from ASB associated with the commercial premises at Block B and is supported.

The bus stop on Old Street should be relocated to the west to divert persons from using the Old Street entrances to the site (para 10.56).

Gates either side of the main east-west route would delineate the areas that are public and those that are semi-public. Access through the site should be defined and designated. The inclusion of street furniture, chicanes and defensible space is supported. Blank walls or gable ends may benefit from planters.

The proposed amenity area has good natural surveillance and the proposed non-locking gates would provide some delineation of this space for the residents. These gates should not be either permanently open or closed.

Proposed lighting should be in the form of lamp posts with 'combat sockets' allowing mobile CCTV units to be installed on any lamp post in an area experiencing a problem. CCTV is recommended for the entrance/exists to the garaged parking area. (para 10.60 and Condition 37)

8.7 **Historic England** – The application should be determined in accordance with national and local policy guidance, and on the basis of your specialist conservation advice.

- 8.8 **Historic England (GLASS)** – Although the site does not fall within an Archaeological Priority Area, the submitted Historic Environment Assessment indicates that the site lies immediately to the north of the Roman Road which is believed to have followed the line of Old Street. Additionally the site is located within the hinterland of a medieval settlement, there is potential for Civil War defences and an internment associated with the former 'Pest House' on the site. As such, a condition (Condition 7) and an informative (Informative 9) are recommended.
- 8.9 **Thames Water** – No objection subject to a condition (Condition 10) requiring details of impact piling method statement and an informative (Informative 5).
- 8.10 **Council for British Archaeology** – No response received.
- 8.11 **London Fire and Emergency Planning** – Block A should include dry risers and the proposal should be laid out in accordance with part B5 of the building regulations (Informative 10).
- 8.12 **London Underground** – No comment.
- 8.13 **Transport for London (Road Network Development)** – No objections.
- 8.14 **NHS Islington (Primary Care Trust)** – No response received.
- 8.15 **UK Power Networks** – No response received.

Internal Consultees

- 8.16 **Planning Policy** – Given the demand for smaller social rented units, downsizing and site constraints, including the need to re-provide certain non-residential floorspace, the dwelling mix is acceptable. Furthermore, site allocation BC18 does not specify a quantum of family housing.

The community centres, dentist and retail units would be re-provided on and off site in accordance with policy. The health centre has been re-provided within the borough and its loss is not resisted.

The demolition of the health centre, delineation of the routes and improved legibility would achieve an objective of the Site Allocation and Finsbury Local Plan.

The improvements to the internal layout of the estate would be compromised by gating off access between Old Street and the streets to the north for non-residents, particularly in winter months (when darkness comes earlier), and would reduce the opportunities for natural surveillance from pedestrian throughput. The proposed gates to Old Street are contrary to policy and not supported.

- 8.17 **Design and Conservation Officer** – Has been involved throughout the pre-application and Design Review Panel (DRP) process and support the proposal. The scale and massing of the proposed development has been amended to ensure that the proposal would not detrimentally impact upon the setting or views of St. Luke's Church and St. Luke's Conservation Area. The proposal is supported subject to conditions.
- 8.18 **Access and Inclusive Design Officer** – Has been involved through the pre-application process. The wheelchair accessible units on the revised plans are acceptable. However, through floor lifts are not detailed on the plans for unit types 14 and 15. While there is sufficient space within Block B for the provision of a platform lift, this should be installed at the time of construction (para 10.72). The proposed mobility scooter stores should be located within 20 metres of the lift core of each block (para 10.74). Further details of the storage units are

requested (Condition 21). A safe drop off point and accessible cycle storage should be provided (para 10.71 and 10.199).

Permeability, movement and multi-functioning spaces are the aim of the Streetbook SPD and the introduction of controlled gates to Old Street is counter-productive to this. The chicanes should also be accessible to wheelchair users.

- 8.19 **Energy Conservation Officer** – No objection.
- 8.20 **Lead Local Flood Authority** – All blue roofs are required to be blue/green roofs (Condition 24). No objection subject to a condition requiring the submission of a SUDS maintenance plan (Condition 25).
- 8.21 **Transport Planning Officer** – The reduction in parking and the level of cycle parking provision is supported. Objection raised to the use of Old Street for servicing. All new units should have rights to obtain residents on street parking permits removed. The provision of minibus parking is an inefficient use of land and it is unclear if this is an operational requirement. No evidence is supplied to justify the provision of gates to Old Street.
- 8.22 **Highways** – No objection to relocation of vehicular access.
- 8.23 **Tree Preservation / Landscape Officer** – Generally in agreement with the categorisation of the trees within the submission.
- The loss of three large canopy trees (T16, T17 and T18) should be resisted and any tree removal must have over-riding justification and appropriate mitigation, including replanting and canopy cover replacement.
- If minded to approve the application, conditions are recommended relating to the protection of retained trees and the provision of replacement trees.
- 8.24 **Refuse and Recycling** – No objection.
- 8.25 **Public Protection** – No objection raised subject to conditions regarding sound insulation, noise levels, winter gardens, mechanical ventilation and construction management.
- 8.26 **Camden and Islington Public Health** – No objection.
- 8.27 **Biodiversity and Nature Conservation** – No objection subject to condition requiring details of bird and bat boxes (Condition 33).
- 8.28 **Greenspace** – No response received.

Other Consultees

- 8.29 **Members' Pre-application Forum** – 28th July 2014.
- 8.30 **Design Review Panel** – At pre-application stage the proposal was considered by the Design Review Panel on the 8th July 2014. The Design Review Panel provides expert impartial design advice following the 10 key principles of design review established by the Design Council/CABE. The panel's observations are attached at Appendix 3 but the main points raised in the most recent review are summarised below:
- The Panel supported and welcomed the improvement of the estate, in particular the relationship with Old Street and the connectivity with surrounding areas. It was felt that more

clarity was needed in relation to the scope of the proposed works and that, in the long term, the works should be considered in the context of larger ambitions for the estate.

Officer response: although the scope of proposed works does not go beyond the estate, the designs of the proposals are informed by the wider area's context including connectivity and building heights in the surrounding area. The applicants have successfully addressed the wider context in delivering a proposal for the site.

- The Panel were generally positive about the architectural language for the new blocks though pointed out that Block B lacked the resolution that was seen on the other blocks. It was also highlighted that Block C needed improvement in relation to amenity and quality of its frontages and that the design team should consider setting this building back from the street.

Officer response: Block B has now been further developed and is a well-considered response to its corner location. The ground floor of Block C has now been pushed back at the front and rear to provide improved amenity to future residents.

- The Panel did not support the concept of a gated development as it goes against general urban design best practice and were apprehensive that the proposal lacked a clear diagram of permeability, connectivity and circulation;

Officer response: Lockable gating has been reduced (as proposed by the applicant) to the two entrances to Old Street and the proposal includes a clear hierarchy of routes through the estate. Officers do not support locking of gates and condition 8 prevents this.

- Panel members were concerned about the resolution of the northeast corner of Block A where it showed the use of transparent material / glass but it was indicated that there would be a bike store behind. The Panel asked the design team to revisit this area to ensure there would be no harmful impact on the quality of the streetscene.

Officer response: The ground floor of Block A, including the façade of the bike storage is now detailed in a red brick consistent with boundary materials across the estate.

- There was some discussion surrounding the choice and quality of materials. Panel members suggested that the design team should think about the estate's evolution and whether it would be more appropriate to reinforce the estate's current separation from everything around it or to gradually break down the 'estates' singularity and create more integration.

Officer response: The new buildings are designed to incorporate a lighter red brick at ground floor level on the outward facing elevations of the estate that would reference the predominant brick colour across the estate, with a darker red/brown brick used at upper floor level both referencing the existing estate and breaking down the estates singularity. All three of the proposed buildings feature a similar character and palette of materials but with Building A including a higher level white brick that responds to the wider context by providing a strong landmark building. The architectural character of buildings B and C responds more closely to the immediate context, reflecting the similar scale to the existing estate buildings.

- Concerns were raised regarding the character of the estate and its amenity spaces. Panel members were concerned that the proposals indicated a series of quiet spaces with the absence of formal play areas and that those spaces did not seem to complement each other. They felt that a more holistic approach in relation to the amenity spaces was required. For example, it was indicated that the design of the new square needed to be informed by the use of the other amenity spaces otherwise there would be a risk of long-term implications on the use and quality of those spaces.

Officer response: The site restrictions result in limited space for the provision of dedicated play equipment, which is reflected in the Finsbury Local Plan, which details that informal play should be incorporated in shared space. The proposed play space would provide incidental play of a good quality spread across the estate, with additional play space provided within private gardens and the community centre. When considered in the context of wider local provision of play space this is considered to provide an adequate level of play space at the site.

9 RELEVANT POLICIES

National Guidance

- 9.1 The National Planning Policy Framework 2012 seeks to secure positive growth in a way that effectively balances economic, environmental and social progress for this and future generations. The NPPF is a material consideration and has been taken into account as part of the assessment of these proposals.
- 9.2 Since March 2014 planning practice guidance for England has been published online.
- 9.3 On the 28th November 2014, a Ministerial Statement and revision to the Planning Practice Guidance (PPG) were published.
- 9.4 In considering the relevance of the changes to the NPPG in light of the NPPF requirement to meet the full objectively assessed needs for market and affordable housing, the Council is mindful that the NPPF sets out the government's national planning policy.
- 9.5 Furthermore, planning legislation (Section 70 of the Town and Country Planning Act 1990 and section 38 of the Planning and Compulsory Purchase Act 2004) provides that planning applications should be determined in accordance with the Development Plan unless material considerations indicate otherwise.
- 9.6 The Council considers that the material consideration of the NPPG should not outweigh the Development Plan, given the specific circumstances in Islington.
- 9.7 Under the Ministerial Statement of 18 December 2015, the government seeks to increase the weight given to SUDS being delivered in favour of traditional drainage solutions. Further guidance from the DCLG has confirmed that LPA's will be required (as a statutory requirement) to consult the Lead Local Flood Authority (LLFA) on applicable planning applications (major schemes).

Development Plan

- 9.8 The Development Plan is comprised of the London Plan 2015 (Consolidated with Alterations since 2011), Islington Core Strategy 2011, Development Management Policies 2013, Finsbury Local Plan 2013 and Site Allocations 2013. The policies of the Development Plan that are considered relevant to this application are listed at Appendix 2 to this report.

Designations

- 9.9 The site has the following designations under the London Plan 2015 (Consolidated with Alterations since 2011), Islington Core Strategy 2011, Development Management Policies 2013, Finsbury Local Plan 2013 and Site Allocations 2013:
- Bunhill and Clerkenwell Core Strategy Key Area
 - Finsbury Local Plan Area (BC3 – Old Street)

- Site Allocation BC18 (Redbrick Estate)
- Central Activities Zone
- Site of Importance for Nature Conservation (SINC)
- Designated Open Space (Old Street Verge)
- Major Cycle Route (Bath Street)
- Local Cycle Route (Old Street)

Supplementary Planning Guidance (SPG) / Document (SPD)

9.10 The SPGs and/or SPDs which are considered relevant are listed in Appendix 2.

Environmental Impact Assessment

9.11 An EIA screening was not submitted. While the proposal would constitute Urban Development on a site over 1 hectare falling within Schedule 2 development of the EIA Regulations (2011), the development does not include more than 150 dwellings and is not considered to be within a sensitive area. As such, an EIA screening is not necessary in this case.

10 ASSESSMENT

10.1 The main issues arising from this proposal relate to:

- Land use
- Design and Heritage (including safety and security)
- Density
- Accessibility
- Landscaping, Trees and biodiversity
- Neighbouring amenity
- Quality of residential accommodation
- Dwelling mix
- Affordable housing (and financial viability)
- Energy conservation and sustainability
- Highways and transportation
- Planning obligations/mitigations/CIL

Land-use

10.2 The site is predominantly in residential use with five areas designated as Sites of Importance for Nature Conservation (SINC) with a small area of designated Open Space beyond the south eastern corner of the site. The site is allocated as site BC18 in the Finsbury Local Plan. The allocation is for “*redevelopment for residential uses (including family housing) retail and community floorspace, open space, car parking and improved pedestrian through-routes.*”

10.3 The proposal consists of the demolition of a vacant health centre, a community centre and a youth project centre (all D1 use class), two professional service units (A2 use class) and a dentist (D1 use class) and the construction of 55 new homes, a community centre (D1 use class), two flexible retail/professional services units (A1/A2 use class), a new amenity space and extensive landscaping and boundary works across the estate.

10.4 Policy CS12 of the Islington Core Strategy 2011 provides a clear direction of seeking new housing of good quality to meet identified and pressing housing needs, particularly affordability and inclusivity needs. The development on Council land of housing that maximises affordable housing provision is key to delivering these policy aims.

- 10.5 The proposal results in the loss of four social infrastructure uses; a vacant health centre, a community centre (Vibast), a youth project centre (Spectrum) and a dentist (The Old Street Dental Clinic).
- 10.6 Policy DM4.14 of the Development Management Policies resists the loss or reduction in social infrastructure unless a replacement facility is provided that would meet the need of the local population for the specific use. Where the specific use is no longer required on site it should be demonstrated that the proposal would not lead to a shortfall in provision for the specific use, that there is either no demand for another suitable infrastructure use on site or that the site/premises are no longer appropriate for such a use and that any replacement facility provides an equal level of accessibility and standard of provision.
- 10.7 Block A includes the provision of a new community centre that would replace the Vibast Centre. The new community centre would provide a higher quantum of floorspace at 379.95 square metres than the existing centre, which measures 259 square metres, it would re-provide the same services, including a TMO office and external space and would be accessible. This represents an acceptable on-site replacement.
- 10.8 It is proposed by the applicant to relocate the dentist and youth project centre to an offsite location at 69-85 Old Street. Planning Permission ref: P2015/1163/FUL was recently granted at Islington's Planning Sub-Committee B on 29th June 2015 for a change of use at 69-85 Old Street to accommodate the dentist and youth project centre. The replacement facilities would be located within 350 metres of their current location, would be highly accessible, would have a greater quantum of floor space than the existing units and would provide the same or an improved level of service. The Directors' Agreement secures the provision of this replacement facility and ensures that it is operational prior to the demolition of the dentist and youth project centre.
- 10.9 The proposal includes the loss of a vacant health centre on the east side of the site. The health centre has been vacant since March 2012 and the services that were provided have been relocated by the Camden and Islington NHS Trust to the Highgate Mental Health Centre on Dartmouth Park Hill and the Islington Assertive Outreach Team (AOT) at Greenland Road, Camden. The replacement facilities provide the same service, are located in highly accessible locations and continue to serve local residents. With regard to potential demand for another suitable social infrastructure use of this building, the applicant has identified anti-social behaviour issues with the current building; while the overall need to increase the supply of social rented housing, the re-provision of other community uses on site and the need to provide open space is considered to outweigh the requirement to re-provide the health centre on-site.
- 10.10 Policies DM4.1 and DM4.7 of the Development Management Policies 2013 seek to protect small and independent shops, and dispersed shops located outside of Town Centres and Local Shopping Areas. Policies BC3 and BC8, and Site Allocation BC18 of the Finsbury Local Plan (2013) encourage the provision of active retail frontages onto Old Street.
- 10.11 The proposal would involve the loss of a Print Shop (A2 use), a Photographers Studio (A2 use) and a Betting Shop (Sui Generis use). The proposal includes the re-provision of two flexible A1/A2 uses, representing a quantitative and qualitative improvement, while also providing active frontages onto Old Street and Bath Street. With regard to the Betting Shop, there is no policy requirement for the re-provision of this, as such, its loss is acceptable.
- 10.12 Policies CS15 of the Islington Core Strategy 2011 and DM6.3 of the Development Management Policies 2013 seek to protect all local open spaces (including semi-private open space on estates), whilst improving their quality and function, and improving access to open space, particularly in those areas that currently have little or no open space locally. Policy CS15 identifies underused spaces on Council housing land to deliver these aims. Site

Allocation BC18 states that the loss of the green space adjacent to the Vibast Centre would only be appropriate where additional semi-private amenity space is created.

- 10.13 The proposal would involve the loss of an area of semi-private amenity space to the rear of the Vibast Community Centre at the western end of the site, with Block B being proposed in this location. The semi-private space proposed to be lost measures approximately 250 square metres. However, a small extent of this area would be retained (approximately 85 square metres), whilst the proposal includes the provision of new publicly accessible amenity space measuring 698 square metres. Overall the proposal would result in a net gain of 542 square metres of open space across the estate. This, together with the wider landscape improvements and benefits provided would mitigate the loss of the semi-private open space, adjacent to the Vibast centre.

Conclusion:

- 10.14 The proposal would introduce new affordable housing to address housing needs within the borough, it would improve the quality and quantity of amenity space across the estate addressing deficits in open space, it would re-provide a community centre and replace the social infrastructure and commercial services across the site. As such, it is considered that the proposal is acceptable in land use terms, subject to an assessment of all other relevant policy and any other relevant material planning consideration.

Design and Heritage

- 10.15 For the purpose of considering the design of the proposal the assessment has been split into relevant sections with a conclusion provided.
- 10.16 Block A: would introduce a part nine and part four storey block to the south east corner of the site. This block would replace a two storey block of little architectural merit, the loss of which is not resisted.
- 10.17 With regard to scale and massing, Block A would be formed of a four storey base fronting Old Street with a nine storey element set 6.5 metres back from the frontage, and rising to a height of 29.9 metres. The set back of the main building height from Old Street, together with the elevation treatment and detailed design (see below) would ensure that the actual and perceived massing of the building would be minimised.
- 10.18 Although not constituting a tall building (defined as 30 metres in height), policy BC9 of the Finsbury Local Plan sets out that building heights must respond to the local context. The proposed building would be comparable to the existing and emerging building heights along this part of Old Street. This context comprises Newland Court immediately to the east of the site that is marginally taller at 10 stories in height, while the Planning Committee recently (24/03/2015) resolved to grant planning permission at 148 Old Street opposite the site for the erection of a seventh and eighth floor extension resulting in a nine storey building. Beyond this on the south side of Old Street there are buildings of six and seven storey height, with tall buildings located on the western side of Old Street Roundabout, a 20 storey tower at St Luke's Estate to the east and two 17 storey towers at the Pleydell Estate to the north.
- 10.19 It is acknowledged that Block A would be significantly higher than the existing building heights within the Redbrick Estate, however the building is designed to address and be read in the context of Old Street, rather than the inward/courtyard design prevalent across the Redbrick Estate. In this context, Block A is considered to be of an appropriate scale and massing.
- 10.20 At ground floor level, the lighter red/orange brickwork would form part of a wider 'ribbon' effect, that together with the proposed and existing boundary treatment and other blocks, would define the extent of the Redbrick Estate and tie the proposals together. The shopfronts would

incorporate a traditional repeated brick pilaster and shop window design and would provide an active frontage onto Old Street and Bath Street, in accordance with policies BC3 and BC8, and Site Allocation BC18 of the Finsbury Local Plan (2013). The lighter red/orange brick would continue around the north elevation of the block, up to the refuse store and Tenants Management Organisation (TMO) offices providing a visual link to the Redbrick Estate in views from Bath Street.

- 10.21 The residential entrance to the block would be from Bath Street with a large glazed entrance incorporating perforated metal detailing to match those across the estate and would continue the residential frontage onto this part of Bath Street formed by Block C.
- 10.22 The upper section of the building has two distinct elements, a brown/red brick element forming a base that extends up to and around a set-back white brick element. The use of white brick, the projection to the west and set in on the east, together with the strong grid layout of the recessed windows and balconies would give this part of the building the appearance of a framed element set within the more solid volume of the darker brick elements that are at lower level or set back from Old Street. This, together with the significant set-back of the nine storey element helps to successfully break down the massing of the building when viewed from Old Street and from within the estate, while also helping to reinforcing its verticality.
- 10.23 The upper floor elements would have deep window reveals (Condition 4) with raked aluminium cladding to the side and recessed balconies to articulate the façade. Notwithstanding this continuity, the windows in the white brick element would have a different layout compared to those in the darker brick element, which (together with the two different aluminium window frame and panelling finishes) would further break up the elevations. Although Block A would incorporate projecting balconies on the north elevation which are generally resisted by the Islington Urban Design Guide (2006), these would add depth and articulate this otherwise flush elevation.
- 10.24 The scale and massing of Block A would be in keeping with the context of this part of Old Street, the design and materials of the building would reference the buildings at the Redbrick Estate at lower level, while introducing a high quality contemporary building that would add to the emerging townscape of this part of Old Street on the upper levels. The images below show the two primary elevations:

3D image from Old Street



Bath Street elevation



10.25 With regard to the setting of the St Luke's Conservation Area and the statutorily grade I listed St Luke's Church to the west of the site, views from Old Street roundabout are characterised by the wide highway and pavements, mature trees on the north side of Old Street and buildings of various height, design and age fronting onto the pavement. As set out above, Block A would form a continuation of the building heights along this part of Old Street, while the set back of the higher element would reduce its massing and ensure that it would not appear overly prominent in views into, out of or within the conservation area. The stepped massing of the building has been designed to ensure that the massing of the building where it fronts Old Street is reduced and to protect views towards St Luke's Obelisk Spire, which would be maintained. By reason of those design characteristics, Block A would not detract from the character, appearance or setting of the conservation area nor detrimentally impact upon the setting of or views of St Luke's Church.

10.26 Community Centre: The proposed community centre would extend from the west elevation of Block A with a raked façade projecting out beyond the front elevation of the adjoining building. The main part of this building would have black zinc clad elevations with a sculptured roof sloping down from the front elevation to where it would meet a saw tooth roof with rear facing rooflights. The front of this building would include a sliding gate formed of layers of laser cut metal with lettering. When open the gate would form part of the main building frontage, appearing abstract, whereas when closed outside of operating hours it would secure the courtyard and display the main centre signage. The images below detail the Old Street frontage, inclusive of the retracted gate and the sculptured roof design:

Old Street frontage



3D image of roof form

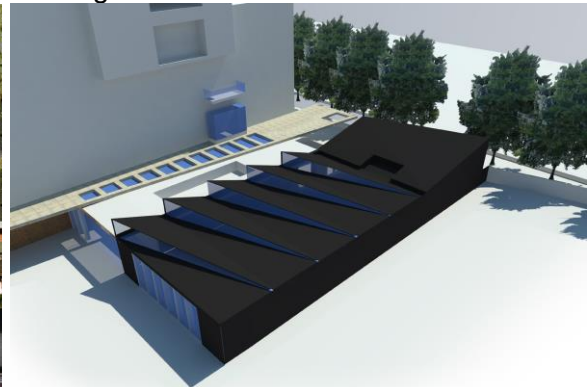

10.27 To the rear the community centre would have a simple elevation with a large glazed opening onto an amenity space. The community centre would be linked to Block A by a largely glazed link element set down from the height of the main part of the community centre. This element would be set back from the frontages of Block A and the black zinc clad building, with the concrete banding at Block A continuing above part of the roof and projecting out to form an entrance canopy.

10.28 The proposed link element, with the continuation of the concrete banding would provide a visual link to Block A, while the use of contrasting materials, the feature gate and the distinctive design, together with the projection of the canopy over the pavement would reflect the buildings role as a public building. This would signpost the community centre and provide an active frontage onto Old Street, in accordance with the aims of the Finsbury Local Plan. Furthermore, the proposed community centre, together with the proposed landscaping would provide a distinctive marker building at the terminus of the Promenade of Light.

10.29 Block B: would introduce a part two and part three storey block fronting onto Old Street and would replace an existing community centre building and amenity space. The community centre is of little architectural merit and therefore its loss is not resisted and while the loss of the green space is unfortunate, the principle of this has been address above (there is a net increase in amenity space across the estate).

10.30 The proposed block would have a ground floor shopfront with full height glazing and orange/red brickwork, with the upper floors separated by a concrete lintel and brown/red coloured bricks. The upper two floors would overhang the ground floor elevation facing Old Street and St. Luke's Close, with a step down to two storey height at the eastern end and to the rear.

Old Street elevation



St Luke's Close elevation



10.31 Where the estate fronts onto Old Street it is dominated by high, largely unbroken brick work, resulting in a large extent of inactive frontage on this side of Old Street. Policies BC3 and BC8, and Site Allocation BC18 of the Finsbury Local Plan (2013) seek to address this by encouraging the provision of active frontages onto Old Street. The proposed Block B would have a ground floor shopfront and residential windows at upper floor levels fronting onto and providing an active use to this part of Old Street. The images below show the existing and proposed Old Street frontage:

Existing



Proposed



- 10.32 Although marginally higher, the form and scale of the proposed block, together with the use of facing brickwork and a concrete lintel is a contemporary interpretation of the existing residential blocks across the estate. The use of recessed windows with raked brickwork, recessed balconies, the use of shadow gaps and a projecting bay window would articulate the elevations of the building and help to visually break up the mass of the block.
- 10.33 The ground floor red/orange brick is a feature of all of the proposed buildings, which together with the existing and proposed boundary treatment defines the boundary of the estate. Although the use of a brown/red brick at upper floor level would represent a departure from the dominant red brick employed across the estate, this would be a subtle change where the building is also viewed in the context of Old Street. The other design features ensure that the building is still read in the context of and compliments the Redbrick Estate.
- 10.34 This, together with the modest scale of the development would ensure that Block B would not detract from the character, appearance or setting of the adjacent St Luke's Conservation Area or the setting of the grade I statutorily listed St Luke's Church immediately to the east of the site. Furthermore, the modest scale and massing of the building is comparable to that of the existing residential buildings at the site and would ensure that views of St Luke's Church Obelisk Spire would be maintained along Old Street.
- 10.35 Block C: would introduce a four storey residential block with a recessed ground floor frontage and gardens onto Bath Street with a single storey projection to the rear (west). The proposed block would partially replace and adjoin the partially rebuilt two storey garage block in the same location. The garage block is of little architectural merit and as such its partial loss in design terms is not resisted.
- 10.36 The proposed block would have brick elevations, a defined lintel running-around the elevation between the ground and first floor, and repeated shadow gap. The use of facing brickwork, a lintel breaking up this brickwork and the inclusion of a recessed ground floor fronting Bath Street (and projection to the rear) is reflective of the existing buildings on the estate. Furthermore, this addresses questions raised by DRP regarding the architectural detailing of the elevations of this block. The images below detail the scheme presented to DRP and the current proposal:

DRP scheme:

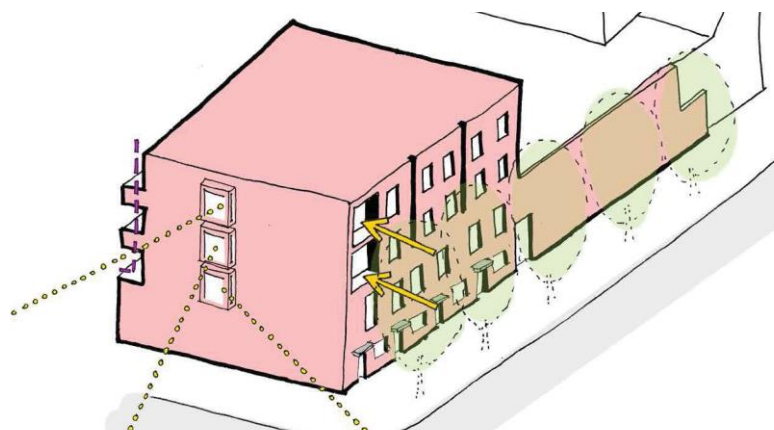

Proposed Bath Street elevation



West elevation



10.37 As with Block A and B, the proposal for Block C would use orange/red brick at ground floor level onto Bath Street, a feature of all of the proposed buildings, that together with the existing and proposed boundary treatment defines the boundary of the estate. The change in brick colours was in response to DRP concerns at the previous design's significant use of red brick. The upper floor brickwork would be of a brown/red colour, which would represent a subtle departure from the dominant red brick employed across the estate. Views of the flank elevation facing Cope House would be limited by the street trees and the two storey garage building, with four windows breaking up that façade.

10.38 The use of recessed windows with raked brickwork, recessed balconies onto Bath Street, projecting balconies on the rear elevation, bay windows on the flank elevation and shadow gaps would articulate the elevations of the building, whilst also providing a vertical rhythm to the block that would reflect the verticality of the buildings on the opposite side of Bath Street and Block A.

10.39 Although higher than existing residential buildings at the estate, together with Block A this block would be viewed in the context of the higher buildings along Bath Street and would relate to the four storey element of Block A. Furthermore, Block C would act as a transitional building from the nine storey height of Block A, frame the proposed amenity and shared space within the estate to its rear and together with Cope House bookend the garage building.

10.40 Garages: The existing two storey garage at the site presents an inactive, unbroken and dominant facade onto Bath Street. The proposed works to the garage would introduce textural brickwork, laser cut metal panelling, continue the concrete lintel from Block C and introduce openings. Additionally, black railings would be added at roof level and a sedum roof introduced. On the rear elevation, the existing ramp would be replaced providing access to the ground and first floor levels of the car park. The image below shows the refurbishment works to the Bath Street elevation and part of Block C:



10.41 Stores: A number of stores are proposed to be installed across the estate, providing cycle parking, pram storage and mobility scooter storage. This comprises 7 groupings of cycle stores and 2 sets of mobility scooter stores at ground level and 3 groups of storage units at landing level across the estate.

- 10.42 The proposed ground level stores are proposed to be of a small scale and include green roofs. These stores are sited along pedestrian routes through the estate and integrated into the landscape strategy. A condition is recommended requiring full elevational details of the stores to be submitted (Condition 21).
- 10.43 The landing level stores would be 1.1 metres high and set within large open landing areas at Vickery Court, Bartholomew Court and Steadman Court. These would be constructed with simple brick walls and timber doors that is in keeping with the existing stores at the site.

Safety and Security:

- 10.44 Through consultation with residents, the Redbrick Tenants Management Organisation (TMO), Islington's Anti-social behaviour (ASB) unit and discussions with local Police and Community Support Officers; the applicant has identified anti-social behaviour and crime issues at the estate. A high number of representations have also been received as part of the planning consultation process that raise similar issues.
- 10.45 It should also be noted that the Crime Prevention Officer has advised that there have been a high number of calls to the police in the last year (over 100) relating to anti-social behaviour (ASB) and other crimes, with almost half of the calls relating to the area around Steadman Court.
- 10.46 The issues identified include noise disturbance from people traveling through the estate, anti-social behaviour (including rough sleeping, urination, vomiting and drug abuse) at night time; stairwells, bin stores and garages being used for drug dealing/abuse and ASB, arson to bin stores, poor levels of lighting of public routes, low levels of passive surveillance/overlooking, opportunistic burglaries to ground floor units, poor quality boundary structures allowing ease of access to rear gardens and dead spaces, and bikes and motorbikes/mopeds speeding through the pedestrian routes of the estate.
- 10.47 The Finsbury Local Plan (2013) identifies and aims to improve safety and security on the Redbrick Estate as part of wider aims set out in policy BC18 of the Finsbury Local Plan (2013). Policies DM2.2 and DM8.4 of the Development Management Policies 2013 seek the delivery of safe, legible and logical environments. Logic, safety and legibility are essential aspects of an Inclusive Design and inspire a sense of security and promote confidence, minimising the need for active surveillance.
- 10.48 The Islington Urban Design Guide (2006) seeks to maximise natural surveillance of building entrances, streets and public spaces. It also promotes the provision of well-defined routes, spaces and entrances that provide for convenient movement as well as design measures that create a sense of ownership, respect, territorial responsibility and community. Uncertainty of ownership can reduce responsibility and increase the likelihood of crime and anti-social behaviour going unchallenged.
- 10.49 The Secure by Design *New Homes* (2014) design guide sets out that vehicular and pedestrian routes should be designed to ensure that they are visually open, direct, well used and should not undermine the defensible space of neighbourhoods. Where it is desirable to limit access/use to residents and their legitimate visitors, features such as change of road surface (by colour or texture), pillars, brick piers or narrowing of the carriageway may be used. This helps to define the defensible space, psychologically giving the impression that the area beyond is private.
- 10.50 The proposal includes extensive landscape and design features in order to design out opportunities for ASB and crime issues to occur across the site. The proposals seek to better

define the legibility and permeability of the estate, define the use of the spaces (once within the estate) and provide security measures to deter ASB and crime. The proposals comprise the following:

- The removal of a narrow and ill-defined pedestrian route next to the Vibast Community Centre;
- Laying of different types of hardstanding to define a hierarchy of routes through the estate and define semi-private areas;
- Introduction of open concrete and metal 'gateways' and different hardstanding to create 'doormats' defining access points;
- Reduction in width of openings onto Old Street and provision of gates within a concrete frame;
- Renewal/replacement of boundary treatment where this is insufficient for security purposes or vulnerable;
- Introduction of low level walls and railings to defensible space fronting pedestrian routes leading directly from Old Street next to Bartholomew Court and Steadman Court;
- Provision of defensive planting to vulnerable spaces;
- Introduction of planters to define defensible space to the front of ground floor residential properties;
- Provision of new and replacement lighting across the site; and
- Secure entrances/FOB access to existing stairwells and bin stores.

10.51 The introduction of defined entrances, the change in hardstanding compared to the surrounding public realm, the new and replacement lighting and the provision of defensible space and defensive planting along routes would serve to define the estate routes as distinct from public highway and define the estate amenity spaces. This would define a hierarchy of routes through the estate that are convenient for movement and help encourage a 'sense of respect, territorial responsibility and community' to those travelling through the estate in accordance with the Islington Urban Design Guide.

Routes through the estate:

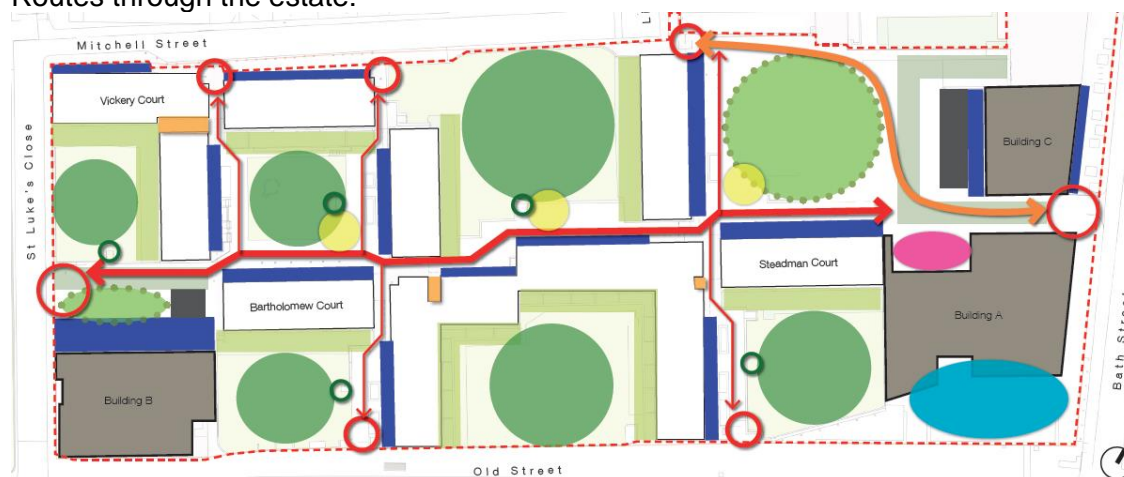

10.52 As noted by the Crime Prevention Officer the provision of defensible space, defensive planting and the renewal/replacement of boundary treatment would reduce opportunities for ASB and

crime across the estate. Additionally, cycle chicanes are proposed across the pedestrian routes to ensure that cyclists and motorbike/moped users would have to slow down to gain access.

- 10.53 Gating: Notwithstanding the above, the proposal includes the introduction of gates to the two Old Street pedestrian accesses and seeks permission for them to be lockable at night. It is noted that the Crime Prevention Officer considers that a reduction in permeability at the site would reduce the level of crime experienced in the area.
- 10.54 Officers have attended meetings with local residents on numerous occasions and understand the concerns raised. However, there are considered to be a holistic package of improvements to the estate that would deter those intent on ASB. It is considered these measures should be given the opportunity to be in and assess how this has reduced ASB. Should evidence remain after the scheme has been fully implemented and in place for a reasonable period, the issue of gating could be looked at again with evidence specific to the improved estate layout and design.
- 10.55 However, the NPPF states that crime should not be seen as a standalone issue, to be addressed separately from other design considerations. The reduction in permeability at the site would be contrary to the aims of policies CS7 and CS8 of the Core Strategy (2011), DM2.2 and DM8.4 of the Development Management Policies (2013), Site Allocation BC18 and policy BC3 of the Finsbury Local Plan (2013) and the guidance within the Islington Urban Design Guide that seek to provide inclusive communities and improve the permeability and legibility of sites (also see paragraph 10.90). As such, a condition is recommended requiring the gates at the site to remain fixed open at all times (Condition 8).
- 10.56 The new buildings proposed have been designed to maximise passive surveillance over existing access routes and the proposed amenity space with high levels of glazing, bay windows, balconies and the internal arrangement of living rooms to front these spaces. Furthermore, the new ground floor residential entrances within the new blocks would provide further activity and overlooking to routes, amenity spaces and other entrances into the estate, while the building designs have been designed to meet the Secure by Design Standards.
- 10.57 The Crime Prevention Officer has noted that the bus stop on Old Street which is located almost immediately to the front of a pedestrian access to the site should be moved to the west. This would likely reduce the amount of people using the Old Street pedestrian access into the estate, particularly at night when night bus services stop here and would therefore be likely to reduce the levels of ASB experienced at this part of the site. The proposed relocation of the bus stop to the west has been discussed on site with TfL and has been found to not be feasible due to the proximity to the junction with St. Lukes Close and the presence of mature trees. The relocation of the bus stop to the eastern end of the site, fronting Block A was also explored, but due to the proximity of the proposed bus stop to the junction with Bath Street, the presence of mature trees and the resultant proximity to an existing interchange bus stop to the east this too was not considered to be feasible.
- 10.58 However, it is considered that the security measures proposed, particularly the defined and narrow entrances from Old Street and the provision of defensible space to ground floor units would be sufficient to address the existing concerns.
- 10.59 It is noted that representations have been received regarding ASB associated with the proposed amenity space. The proposed amenity space would replace the vacant health centre which provides concealed spaces that have been identified as currently suffering from ASB. The new amenity space would be overlooked from Steadman Court, Cope House and Block C, while the open boundary treatment and high stemmed trees would allow passive surveillance from the improved pedestrian link between Bath Street and Lizard Street. The lighting strategy includes uplighting to parts of the amenity space and column lights to define the pedestrian

route. These measures are considered appropriate to deter crime and anti-social behaviour from occurring.

- 10.60 The proposal includes the provision of secure access doors to the stairwells and gated access to the bin stores serving the existing blocks across the estate. These comprise a fobbed access, with a glazed door and perforated metal panel to the stairwells and gates and a perforated metal panel to the bin stores, the design of which would integrate with the wider estate proposals. The provision of doors to the stairwells and gates to bin stores would address issues regarding their use for ASB. Although restricting general access to upper floor level, the stairwells serve as access to private residential entrances and would not impact upon the legibility of the estate. Furthermore, the accesses to the garages would be via secure fobbed entrances.
- 10.61 The proposal includes the provision of CCTV at three points across the estate, two where the north – south routes cross the main east – west route and a further point between the three blocks forming Vickery Court. The provision of CCTV would act as a deterrent and where ASB/crime does occur footage could be retrieved. The Crime Prevention Officer has noted that the proposed lighting columns should be fitted with ‘combat sockets’, which would provide a power source at high level for the installation of a mobile CCTV unit that could then be used in areas where any potential or actual ASB/crime occurs. This is recommended to be required by condition (37).
- 10.62 The proposal includes extensive measures that seek to design out ASB and crime issues across the estate, while the new buildings would provide for informal surveillance and an increased footfall across the estate with vested interest in protecting the sense of community. With the exception of the lockable gates, the proposals are considered to be acceptable and would represent an improvement to the level of safety and security across the estate. Furthermore, the proposal would not prejudice any future means of security that would be subject to a separate application.

Conclusion:

- 10.63 The proposal would introduce three buildings across the estate, providing development of a high quality design with an appropriate scale and which successfully references the established and emerging context of the site and surrounding area. The consistent material palette across all of the proposed buildings, the boundary treatment (as set out in the ‘Landscape’ section below) and the alterations to the existing blocks would also ensure a design coherency across the estate. The proposal includes extensive security measures that would help to design out ASB and crime issues across the estate.
- 10.64 The scheme has been presented to the Design Review Panel who were generally supportive of the design of the new blocks subject to minor alterations that have been included in the submission and with the exception of gating to Old Street (which is prevented by condition 8), were supportive of the proposed security measures.
- 10.65 The overall quality of materials and finishes is considered to be key to the success of the proposal. A condition (4) is attached with regard to window reveals, balcony details and materials to ensure that a development of an appropriate high quality would be delivered. The proposal is therefore in accordance with Policies CS7 and CS9 of the Core Strategy (2011), DM2.1, DM2.2, DM2.3 and DM2.5 of the Development Management Policies (2013) and BC3, BC7, BC9 and BC18 of the Finsbury Local Plan (2013).

Density

- 10.66 The London Plan encourages developments to achieve the highest possible intensity of use compatible with the local context. The development scheme proposes a total of 55 new

residential dwellings comprised of 183 habitable rooms (hr). The existing site incorporates 112 dwellings (comprising 527 habitable rooms).

- 10.67 Density is expressed as habitable rooms per hectare (hr/ha) and is calculated by dividing the total number of habitable rooms by the gross site area. The site covers an area of approximately 1.394 hectares.
- 10.68 In assessing this it is necessary to consider that the London Plan policy notes that it would not be appropriate to apply these limits mechanistically with local context and other considerations to be taken into account when considering the acceptability of a specific proposal.
- 10.69 The site has a public transport accessibility level (PTAL) of 6b (Excellent). In terms of the character of the area, this would be defined as Central by the London Plan. The London Plan for areas of this PTAL rating identifies the suggested residential density range of 650-1100 hr/ha or 140-290 u/ha.
- 10.70 The proposed development has a residential density of 119 u/ha and 509 hr/ha, both of which are below the density range of the London Plan policy. The proposal would therefore not result in an overly dense development. Furthermore, the proposals also increase the amount of amenity space at the estate.

Accessibility

- 10.71 The development is required to achieve the standards of the Islington Inclusive Design SPD and provide 10% (by habitable room) of residential units as wheelchair accessible units.
- 10.72 The application provides 6 wheelchair accessible units amounting to 9.83% of the total number as measured by habitable rooms and 10.9% by unit. Although the number of habitable rooms is short of the 10% required by policy DM3.4, the difference is only marginal and an additional unit is designed in accordance with the principles contained in the 'Housing our Ageing Population Panel for Innovation' (HAPPI) report 2009, whereby the floor area measures 10% larger than minimum standards to allow for future adaptability and includes an accessible bathroom. Furthermore, there are seven proposed accessible parking bays, 6 of which would be allocated to the wheelchair accessible units and the other would provide an accessible visitor parking bay for both the residential and community centre uses, and provide a safe drop-off point.
- 10.73 The applicant has detailed that all 55 units have also been designed to achieve the Council's Flexible Homes Standards (Condition 18). While Block B would not have a lift, this block would provide nine units and in accordance with the Inclusive Design in Islington SPD for a scheme of less than 10 units the space for the future provision of a platform lift has been provided. Although unit type 14 and 15 in Block B do not detail a space for a through floor lift, due to these units having an off-set floor plan across two levels the provision of through floor lifts would not be possible.
- 10.74 The community centre would have level access and an accessible W.C in accordance with the Islington Inclusive Design SPD. The full fit out of the two flexible A1/A2 units has not been detailed as these are proposed as shell and core for prospective occupiers to fit according to their specification. Notwithstanding this these units would have level access and a condition is recommended requiring these units to be constructed in accordance with the principles the Inclusive Design in Islington SPD (Condition 18).
- 10.75 A total of 10 mobility scooter storage spaces would also be provided across the estate. These are not allocated to any particular property and therefore while not necessarily located within 20 metres of any intended users, their provision is welcomed.

- 10.76 A representation has been received that raises concern regarding the accessibility of Cope House by mobility scooter following the development. While the proposal does not include any changes to this property, the pedestrian route running past the front of Cope House would be repaved and would provide a high level of accessibility.

Landscaping, Trees and Biodiversity

- 10.77 Policy DM6.5 states that development should protect, contribute to and enhance the landscape, biodiversity and growing conditions of the development site and surrounding areas. Developments are required to maximise provision of soft landscaping, including trees, shrubs and other vegetation. The proposal includes extensive landscaping works across the entire estate and the provision of new amenity space.

Landscaping:

- 10.78 Site Allocation BC18 states that the estate currently has poor legibility, that the east/west route from Bath Street to Lizard Street should be improved and that the public realm of the estate should be enhanced. Project 17 of the Finsbury Local Plan (2013) is specific to the Redbrick Estate and states that any public space projects at the estate should consider pedestrian movements and desire lines which bisect the space towards Old Street.
- 10.79 Furthermore, the supporting text to policy DM2.1 of the Development Management policies sets out that legible developments are easily understood by their users - they help people to find their way around both the development and the wider area, and to understand how a place works and functions. Developments that promote a successful relationship between public and private spaces have clear public frontages and private rear of buildings, they give a clear indication of ownership and management responsibility for these spaces.
- 10.80 The proposed new amenity space would consist of a raised area with steps leading up on the south west corner to a planted area measuring a total of 698 square metres. Along the north and east sides of the amenity space would be a brick plinth and metal railing surround up to a height of 1.5 metres with clear stem trees planted. The boundary treatment and trees would allow views across this open space while also clearly defining the main pedestrian route from Bath Street to Lizard Street.
- 10.81 Additionally, this route would be further defined by different paving materials, lighting, and concrete lintel framed entrances would be provided at each end of the route. These works would provide visual reference points for those using this route through the estate and improve the legibility of the estate.
- 10.82 The proposed hardstanding would provide a hierarchy of pedestrian routes and define spaces across the estate. The central east to west route through the estate would be repaved with a marked difference in materials between this route and those running north to south. Dark paving would be introduced to the front of ground floor residential entrances throughout the estate, which together with the proposed raised planters would provide a clear separation between pedestrian areas and semi-private residential areas, creating defensible space. Railing chicanes are proposed along each of the pedestrian routes through the estate to prevent cyclists and motorbikes travelling through the estate at speed.
- 10.83 With regard to the entrances/exits at the estate, it is proposed to retain the two vehicular entrances at the east and west ends of the estate, albeit with the Bath Street entrance relocated 1 metre to the south. Although Block B would result in the loss of a pedestrian access at the western end of the estate, that existing pedestrian access is formed of a narrow alleyway set between two high walls that leads to a parking area that is easily accessible from St Luke's Close. As such, its loss would not represent a significant reduction in legibility. The two remaining entrances onto Old Street would be reduced in width with perforated metal

gates set below a pre-cast concrete lintel. While the reduced entrances, over-sailing concrete lintel and perforated metal gates would clearly define the entrances/exits to the estate the gates are proposed to be locked at night for security reasons. Locking of gates is not supported by officers.

Locking of gates:

- 10.84 Policy CS9 of the Islington Core Strategy (2011) states that housing developments should not isolate their residents from the surrounding area in gated communities, while policy DM2.1 of the Development Management Policies (2013) states that 'gated development is generally unacceptable, other than for backland developments where there is no possibility of creating a through-route'. The Islington Urban Design Guide sets out that development should be designed so as to not require a gate to make them secure. In addition to this the Design review Panel (DRP) raised concern regarding the proposed gating and noted that gating was against general urban design best practise.
- 10.85 While, the 'Design' section above addresses security implications, the introduction of gates, even when proposed to only be closed at night would restrict the north to south routes across the site, create a less inclusive form of development and even with the landscape improvements, reduce the current level of legibility contrary to the aims of the Core Strategy, Development Management Policies, Finsbury Local Plan and Islington Urban Design Guide. As such, a condition is recommended requiring the gates at the site to remain fixed open at all times (Condition 8).
- 10.86 Notwithstanding the above, each of the entrances to the site would have defined gate ways and an area of different coloured paving, providing a marked break in paving type or 'doorstep' that would define entrances/exits to the estate. Furthermore, where public views into the estate from entrances face onto rear garden boundary treatment or blank facades it is proposed to either replace the existing fencing or introduce brick walls at the same height as existing, and provide defensive planting.
- 10.87 At present there is a high level brick wall running from the Vibast Centre at the west end of the estate to a mural at the east end of the estate. The height of this wall and large unbroken extents of brickwork result in a largely inactive and somewhat oppressive frontage to Old Street. The proposal would introduce pre-cast concrete lintels that reflect those prevalent across the estate, new brick panels, textural (projecting/recessed) brickwork and perforated metal panels that would add visual interest to this wall. The existing mural at the east end of this wall would be retained.
- 10.88 With regard to the existing green spaces to be retained across the estate these would benefit from additional planting, while a 1.5 metre high boundary brick plinth and railing fence would be introduced to the green space adjacent to Vickery Court to better define this space and new ramped entrances would be installed at the Wildflower Meadow Garden and Wildflower Garden to provide level access.
- 10.89 Further works include, the replacement of some timber fences, the introduction of a low level boundary gate at 10 Vickery Court to provide a single entrance where this is currently shared by two properties and a 1 metre high wall is proposed to replace railings at the east and west ends of the defensible space, to the north of Vickery Court.
- 10.90 The proposed landscaping works would introduce a well-designed amenity space, a hierarchy of routes through the estate, extensive planting and the provision of defensible space to ground floor units. The TMO oversee maintenance of planting across the estate and would continue to do so following the implementation of the proposal. This, together with the use of a consistent and high quality material palette and a restrained lighting strategy would result in a

high quality public realm and subject to the gates to Old Street remaining open the proposal would improve the permeability and legibility across the estate.

Trees:

10.91 The Redbrick Estate has a large number of trees throughout the site consisting of predominantly smaller ornamental trees within the internal courtyards and larger canopy trees on the perimeter and street frontages. The application proposes the removal of 21 individual trees, three of which are dead and additionally three tree stumps would be removed. The table below details the quality of the trees proposed to be removed, expressing this through their British Standard grading, with A being the highest standard (trees of high amenity quality and with potential to improve) and U being the lowest (defined as not being a constraint to development):

| British Standard Category | Tress lost / Percentage |
|----------------------------------|--------------------------------|
| A | 0 / 0% |
| B | 4 / 19% |
| C | 14 / 66.7% |
| U | 3 / 14.3% |

10.92 The majority of the trees to be removed are categorised as class C or below (81%). Category C trees are defined by British Standard BS 5837:2012 '*Trees in relation to design, demolition and construction*' as being of low quality and value. These trees are generally not considered as a restraint to development given appropriate justification for removal and mitigation.

10.93 On the south east corner of the site are a row of mature trees set within two raised planters fronting onto Old Street that form part of the 'Promenade of Lights', while along Bath Street there are a row of street trees. These trees are of good amenity value and are proposed to be retained.

10.94 The proposal includes the loss of 11 trees at the south east corner of the site, four of which are category B trees of considerable size. The trees proposed to be removed within this part of the site are arranged around a parking area with a row of category C trees to the south and three of the category B trees growing through and lifting the asphalt of the parking area. The loss of these trees, particularly the category B trees (with significant canopy cover) would harm the visual amenity of this part of the site. However, these trees are largely set back from the street edges and form part of a denser grouping of trees made up of those on Old Street and Bath Street. While the removal of trees and erection of built form would reduce the visual amenity of this large grouping, the trees to be retained are set forward of those to be removed, maintaining a good level of visual amenity to this prominent corner and complimenting views of Block A and C.

10.95 The application includes the planting of 70 new trees, which represents a 10% increase in canopy area within a 5-10 year period. Of the new trees, 15 have the potential to become large canopied trees and have space available to develop natural canopies. Further tree planting along Bath Street was explored but was found to not be possible. The tree planting forms part of a wider high quality landscaping proposal that would be of a considerable amenity value, in accordance with policy DM6.5.

10.96 Representations and a petition have been received in relation to the loss of trees on the west side of the estate. This area comprises three trees and two tree stumps within the green space

to the rear of the Vibast Community Centre and a tree within a raised planter beyond this. While these four trees have environmental and amenity value, it is noted by the Tree and Landscape Officer that due to their relatively small size and the potential for mitigating re-planting to be achieved it is not inconceivable that the benefits these trees currently provide can be increased. The proposal includes the planting of three trees immediately to the rear of Block B and four trees within the SINC beyond this, which together with the proposed landscape works and retained trees would ensure that the amenity value of this part of the estate would be maintained. Furthermore, any harm to views into and out of the St. Luke's Conservation Area resulting in the loss of trees would be mitigated by replanting.

- 10.97 While it is acknowledged that the loss of the trees would be harmful to the visual amenity of this part of the site, this has to be weighed against the benefits of the proposal, which include the provision of considerable amounts of affordable housing, extensive landscape improvements across the site, the provision of new publicly accessible amenity space, improved security measures across the estate and the provision of a high quality community centre. On balance, the planning benefits of the proposal are considered to constitute overriding planning benefits that would justify the loss of these trees subject to sufficient mitigation.
- 10.98 To ensure a satisfactory standard of visual amenity and the adequate protection of the trees to be retained at the site, conditions are recommended which require the submission of and compliance with an agreed Landscape Management Plan (Condition 13), an Arboricultural Method Statement (Condition 11) and a Scheme of Site Supervision (Condition 12).

Biodiversity:

- 10.99 The site includes five areas of green space designated as local level Sites of Importance for Nature Conservation (SINCs) with St. Luke's Churchyard to the east of the site also designated as a local level SINC.
- 10.100 The submitted Ecology Appraisal concludes that the proposal would not impact upon the SINC at St. Luke's Church and that through protection measures during construction (Condition 5 and 11) the on-site SINCs would not be unacceptably impacted upon. Furthermore, the proposed landscaping scheme includes biodiverse planting throughout the site, biodiverse green roofs and the provision of bird and bat boxes, which would enhance the biodiversity quality of the site. There would be no net loss of SINC area at the estate.
- 10.101 Concern has been raised regarding the loss of tree habitat and the impact of the lighting strategy upon wildlife. The Ecological Appraisal details that the trees to be lost offer negligible potential for bat roosts and that the loss of trees would not impact upon bird nesting if these are removed outside of bird nesting season (or any point where nests are not present). Furthermore, the Council's Biodiversity and Nature Conservation Officer has noted that given the fairly low roosting and foraging potential for bats in this location this is not of concern.
- 10.102 The Council's Biodiversity and Nature Conservation Officer has assessed the submission and considers the proposals to be acceptable.

Neighbouring Amenity

- 10.103 The Development Plan contains policies which seek to appropriately safeguard the amenities of residential occupiers when considering new development. Policy DM2.1 of the Development Management Policies Document 2013 states that satisfactory consideration must be given to noise and the impact of disturbance, vibration, as well as overshadowing, overlooking, privacy, direct sunlight and daylight receipt, over-dominance, sense of enclosure and outlook. Finsbury Local Plan policy BC3 and Site Allocation BC18 support this.

10.104 Overlooking/Privacy: policy identifies that 'to protect privacy for residential developments and existing residential properties, there should be a minimum distance of 18 metres between windows of habitable rooms. This does not apply across the public highway, overlooking across a public highway does not constitute an unacceptable loss of privacy'. In the application of this policy, consideration has to be given also to the nature of views between habitable rooms. For instance where the views between habitable rooms are oblique as a result of angles or height difference between windows, there may be no harm.

10.105 An assessment of overlooking and outlook is set out for each of the proposed blocks below:

10.106 Block A: Although this block would introduce windows and balconies on all four elevations up to nine storeys in height; to the south and east its outlook would be over a highway whilst to the north it would have a significant separation to Cope House of over 39.5 metres, such that there would be no unacceptable overlooking.

10.107 With regard to the west elevation of Block A the four northern most windows at second and third floor level would face towards a fourth floor kitchen window in the flank elevation of Steadman Court. The second floor window in Block A would be set below the height of this kitchen window such that no unacceptable overlooking would be afforded, which would also be the case for the lower level windows and the windows at fourth floor level and above. The southernmost third floor window that is within 18 metres of the neighbouring window at Steadman Court would be set at an oblique angle such that it would not result in direct overlooking. A condition is recommended requiring the three west facing windows serving Unit 11 to be obscurely glazed up to the halfway point of the windows (Condition 9). The images below show the distances to Steadman Court and the level changes as set out above:

Site lines:

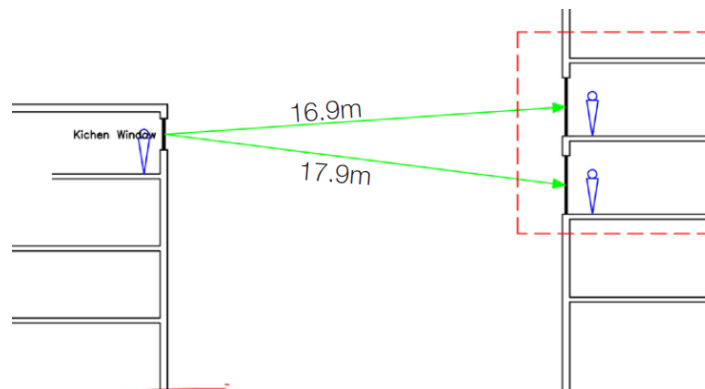

Distance to neighbouring window:

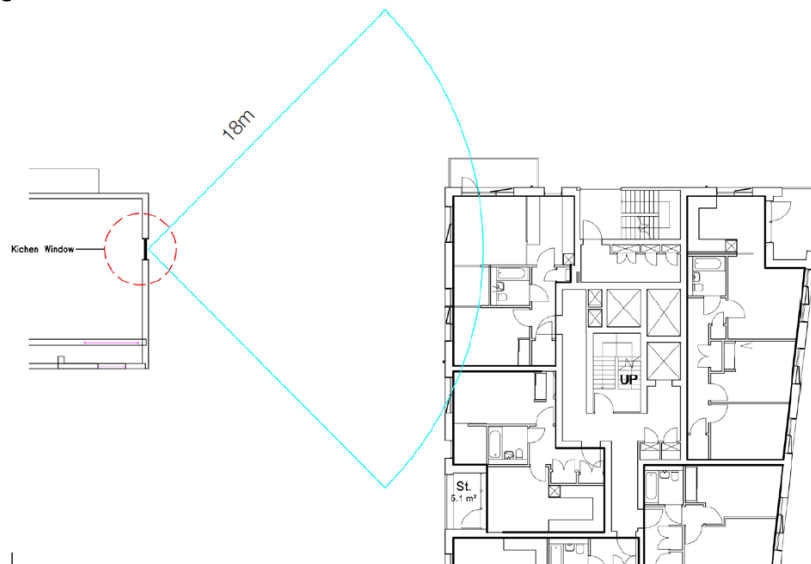

- 10.108 While Block A would undoubtedly be highly visible in views from Cope House, due to its separation of over 39.5 metres (at the closest point) from these properties, the space around the taller element, its verticality (and slim design), that it would be partially screened by Block C and its context amongst other buildings of comparable height, Block A would not be overbearing to the occupiers of Cope House.
- 10.109 To the west of Block A, the eastern projection of Steadman Court would be located 16 metres away. However, this part of Steadman Court has windows orientated roughly north and south, which together with the separation distance would ensure that the taller element of Block A would not be overbearing. Although a kitchen window in the flank elevation of Steadman Court would have an outlook directly facing Block A, it would maintain an open aspect to the north east and maintain an appropriate outlook.
- 10.110 The east facing windows of the southern projection of Steadman Court would be located almost 50 metres from the taller 9 storey element of Block A and would maintain an uninterrupted outlook over open space. The northern projection of Steadman Court has windows with a north easterly aspect that together with a separation from Block A in excess of 50 metres would ensure that Block A would not be overbearing to these occupiers.
- 10.111 To the east Block A would be adjacent to the stair core of Newland Court, a building of comparable height, separated from the site by Bath Street with residential windows facing north and south. As such, the proposal would not be overbearing in views from these properties.
- 10.112 Community Centre: The community centre at Block A would replace an existing two storey building located immediately on the boundary with Steadman Court. The community centre would have a marginally greater depth than the existing building but would have a reduced height with a saw tooth roof design increasing in height as it moves further from Steadman Court. Due to the reduction in height and only marginal increase in depth, the proposed community centre would not result in an increased sense of enclosure or be overbearing even when considered together with the taller 9 storey element. There are no windows proposed in the side elevation that would result in overlooking and the front and rear windows would face onto Old Street and an enclosed space serving the community centre to the rear.
- 10.113 Block B: This block would be set over 40 metres to the western projection of Vickery Court ensuring no unacceptable overlooking, while any views towards the west facing elevation of the southern projection of Vickery Court would be at an oblique angle. However, there are three windows in the south elevation of Vickery Court at second and third floor levels that would be located within 17.3 metres of ground and first floor windows in Block B and 17.9 metres (at the closest point) of the second floor terraces above this. Of the neighbouring windows at Vickery Court, at second floor level one window is a high level window with a minimal opening size, such that there would be no unacceptable overlooking. The second floor windows in Block B would be set below the cill height of the larger second floor window at Vickery Court and well below the third floor window, such that there would be no overlooking from these windows. The roof terraces in Block B, due to the parapet and balustrade would be set further back from the rear elevation of this building. The set back together with the change in heights to the second floor window at Vickery Court would result in a separation distance of 18 metres, which is in accordance with policy. Notwithstanding this, while the view from the terraces towards the neighbouring third floor windows would be within 18 metres, a condition is proposed (Condition 9) requiring the provision of privacy screens to the two relevant roof terraces that would ensure that there is no overlooking.
- 10.114 The eastern most roof terrace within Block C would be afforded views back towards the windows in Bartholomew Court. Due to level changes the ground and first floor windows in Block B would not result in any overlooking while the roof terraces would not have views into the fourth floor kitchen window of the neighbouring property. However, the roof terraces

servicing units 40 and 41 would be located within 18 metres of a bedroom window at Bartholomew Court and at a higher level. As such, a condition is recommended (Condition 9) requiring the erection of a privacy screen to mitigate this potential for overlooking.

Site lines:

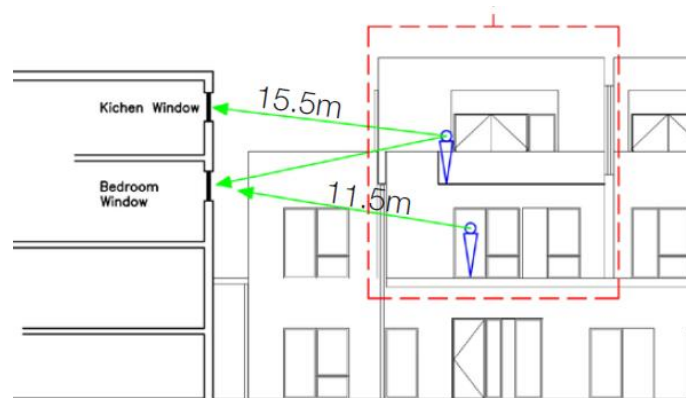

Distance to neighbouring window:

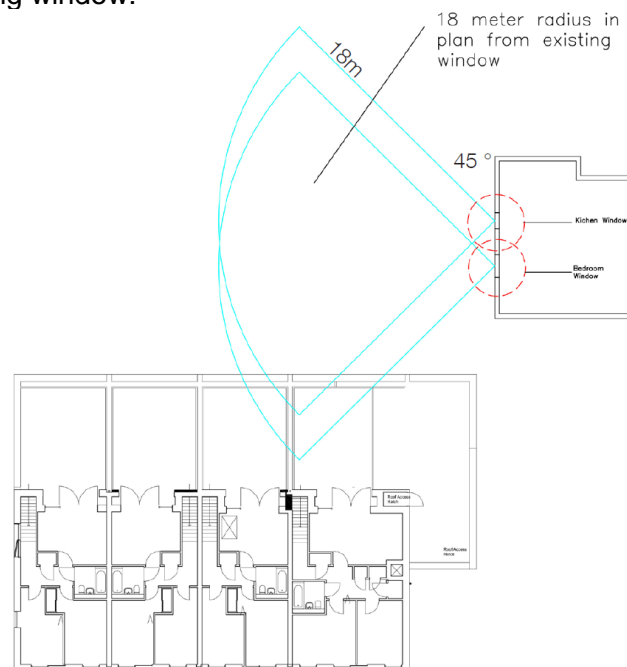

10.115 Block B would be set to the west of Bartholomew Court beyond their rear gardens. The closest element of Block B would be two storeys in height with the three storey element set away from both the rear and west elevations, which would reduce the massing of the building when viewed from the rear elevations of the properties at Bartholomew Court. The modest height and set back of the proposal, together with the open outlook from the windows of these neighbouring properties would ensure that Block B would not be overbearing or result in a sense of enclosure to the occupiers of Bartholomew Court.

10.116 The proposed Block B would be located a significant distance from Vickery Court (the northern most block of this name) with a modest height, which together with the orientation of the windows within the southern elevation of Vickery Court would ensure Block B would not be overbearing or result in an unacceptable sense of enclosure .

10.117 Block C: To the east the windows in this block would face over a highway and would not result in any overlooking having regard to planning policy. The windows and balconies in the rear elevation of this block would be located a significant distance from any neighbouring properties such that they would not result in overlooking.

- 10.118 Block C would be located over 19 metres from Cope House and set over the footprint of the existing garage building, adding two and half storeys to the southern end of the garage building. Its four storey height is comparable to the existing buildings at the site and set below those to the east and proposed to the south. Due to its modest height, the separation distance from the neighbouring properties and the space around the building, it would not be overbearing or result in an unacceptable sense of enclosure to neighbouring occupiers.
- 10.119 Garages: The alterations to the garage would maintain the scale and massing of the existing garage building and introduce a green roof. The access ramp to the garage would remain as existing. The resultant garage building would not be overbearing to neighbouring occupiers.
- 10.120 Noise and Disturbance: While introducing additional residents to the site, the proposal would introduce significant landscape and security improvements across the estate that should reduce potential for disturbance. Furthermore, access to the majority of the proposed residential units would be off busy highways outside of the estate, which would further reduce the potential for disturbance.
- 10.121 It is noted that representations have been received regarding potential disruption associated with the proposed community centre. The community centre replaces an existing community centre at the site and a condition is recommended requiring the submission of a Community Centre Management Plan to ensure that any potential disturbance is mitigated (Condition 17).
- 10.122 Retail and Professional Services uses are generally considered to be compatible with residential uses and the hours of operation are recommended to be controlled by condition (Condition 16).
- 10.123 Daylight and Sunlight: The application has been submitted with a sunlight and daylight assessment. The assessment is carried out with reference to the 2011 Building Research Establishment (BRE) guidelines which are accepted as the relevant guidance. The supporting text to Policy DM2.1 identifies that the BRE 'provides guidance on sunlight layout planning to achieve good sun lighting and day lighting'.
- 10.124 Daylight: the BRE Guidelines stipulate that there should be no real noticeable loss of daylight provided that either:
- The Vertical Sky Component (VSC) as measured at the centre point of a window is greater than 27%; or the VSC is not reduced by greater than 20% of its original value. (Skylight);
- And
- The daylight distribution, as measured by the No Sky Line (NSL) test where the percentage of floor area receiving light is measured, is not reduced by greater than 20% of its original value.
- 10.125 It should be noted that whilst the BRE guidelines suggest a 20% reduction in NSL would represent an acceptable loss of daylight within a room, it is commonly held that losses in excess of 50% NSL are not acceptable.
- 10.126 Sunlight: the BRE Guidelines confirm that windows that do not enjoy an orientation within 90 degrees of due south do not warrant assessment for sunlight losses. For those windows that do warrant assessment, it is considered that there would be no real noticeable loss of sunlight where:

In 1 year the centre point of the assessed window receives more than 1 quarter (25%) of annual probable sunlight hours (APSH), including at least 5% of Annual Winter Probable Sunlight Hours (WSPH) between 21 Sept and 21 March – being winter; and less than 0.8 of its former hours during either period.

In cases where these requirements are breached there will still be no real noticeable loss of sunlight where the reduction in sunlight received over the whole year is no greater than 4% of annual probable sunlight hours.

10.127 Where these guidelines are exceeded then sunlighting and/or daylighting may be adversely affected. The BRE Guidelines provide numerical guidelines, the document though emphasizes that advice given is not mandatory and the guide should not be seen as an instrument of planning policy, these (numerical guidelines) are to be interpreted flexibly since natural lighting is only one of many factors in site layout design.

Sunlight and Daylight Losses for Affected Properties Analysis

10.128 Residential dwellings within the following properties have been considered for the purposes of sunlight and daylight impacts as a result of the proposed development:

- 12-30 and 6-29 Bartholomew Court;
- 110 Old Street (No failures);
- 1-28 and 7-35 Steadman Court;
- 11-35 Vickery Court; and
- 1-48 Cope House.

10.129 12-30 and 6-29 Bartholomew Court: With regard to 12-30 Bartholomew Court, the proposed development would not protrude through a 25 degree section line drawn from the centre of the closest lowest window of the existing building and therefore, as set out in the BRE Guidelines the development would be unlikely to have a substantial effect on the diffuse daylight received. As such, assessments for daylight (VSC and NSL) are not required. With respect of sunlight, the relevant windows would retain an ASPH in excess of 25%.

10.130 Although there would be reductions in sunlight to some windows/properties at 6-29 Bartholomew Court, these would be within acceptable levels, i.e. losses less than 20%. Furthermore, there would be no loss in daylight distribution levels. However, one ground floor window would have a reduction in VSC of 24.77%. The 20% reduction is considered to be 'acceptable' by the BRE Guidelines. Reductions in VSC of between 20% - 30% are generally considered to be a lesser/minor infringement and the window affected is served by large extent of glazing with no impact upon the daylight distribution to this room. As such, it is considered that the existing properties would maintain acceptable levels of daylight and sunlight.

10.131 1-28 and 7-35 Steadman Court: The relevant windows in 1-28 Steadman Court are not within 90 degrees of due south and therefore do not require testing for levels of sunlight. Although there would be some reduction in sunlight to the properties at 7-35 Steadman Court these would all be within acceptable levels, with two rooms benefitting from an improved level of sunlight.

10.132 The BRE assessment demonstrates that, with the exception of one window (see below), although there would be reductions in VSC these would all be within BRE Guidelines. With regard to Daylight Distribution, the submitted NSL analysis details that five rooms would receive losses of above 20%. However, a reduction between 20% - 30% is generally considered to be a lesser/minor infringement in urban areas and four of these windows would have reductions between 21.7% and 25.5%. Furthermore, these four windows form small high level windows and face onto an open area. Whilst these losses are regrettable, the small size of the windows and the minor/lessor infringement when balanced against the benefits of the scheme is considered to be acceptable.

10.133 With regard to the fifth room, a kitchen window in the east elevation of Steadman Court, an objection has been received regarding the loss of light to this room. This window would experience a 38.06% reduction in VSC and a 39.2% reduction in NSL, above the BRE

Guidelines. However, the actual retained level of VSC would be in excess of 20% and the NSL reduction would be well below 50%, which is commonly held to be the maximum reduction permissible within urban areas. This is an isolated impact and it is considered appropriate to balance this against the benefits of the scheme.

- 10.134 11-35 Vickery Court: The BRE assessment demonstrates that there would be no reductions in sunlight or NSL and although there would be reductions in VSC these are minimal and would be within BRE Guidelines.
- 10.135 1-48 Cope House: The BRE assessment demonstrates that although there would be reductions in VSC, NSL and sunlight levels these would all be within BRE Guidelines.
- 10.136 Taking into account the points set out above it is considered that the impact upon these properties can be accepted.
- 10.137 Overshadowing The BRE guidelines state that to appear adequately sunlit throughout the year at least half of an amenity space should receive at least 2 hours of sunlight on 21st March. The submitted Daylight/Sunlight and Overshadowing Report details that all amenity space (inclusive of the proposed amenity space) would meet BRE Guidelines.

Quality of Resulting Residential Accommodation

- 10.138 Islington Core Strategy policy CS12 identifies that to help achieve a good quality of life, the residential space and design standards will be significantly increased from their current levels. The Islington Development Management Policies DM3.4 sets out the detail of these housing standards.
- 10.139 Unit Sizes: All of the proposed residential units comply with the minimum unit sizes as expressed within this policy.
- 10.140 Aspect: Policy DM3.4 part D sets out that 'new residential units are required to provide dual aspect accommodation, unless exceptional circumstances can be demonstrated'. With the exception of seven units, all of the proposed flats would have a dual aspect.
- 10.141 Within Block A, a first, second and third floor flat (unit type 2) would have a single aspect. However, the windows serving these units are floor to ceiling height, the windows would have a western outlook and the flats have an efficient layout locating more readily used space closer to the windows, while the deep balconies would provide good quality amenity space with a more expansive outlook. This is considered to provide sufficient mitigation in this instance.
- 10.142 The two ground floor units within Block B would be north facing and have a single aspect. Normally policy suggests the refusal of this type of layout. However, both units would have very large floor areas, with an efficient layout and the floor to ceiling height windows would provide an outlook onto generously proportioned private gardens and a landscaped area beyond this. These design features are considered to provide sufficient mitigation in this instance.
- 10.143 The two ground floor units within Block C would be east facing and have a single aspect. However, both units would have large floor areas, with an efficient layout and the floor to ceiling height windows would provide an outlook onto private gardens. Single aspect units that do not face north are less of a concern, and the design provides sufficient mitigation in this instance.
- 10.144 Daylight: Policy DM3.4 requires all residential development to maximise natural light enabling direct sunlight to enter the main habitable rooms for a reasonable period of the day. The BRE Guidelines detail the level of light rooms should receive through the assessment of Vertical Sky

Component (VSC) and Average Daylight Factor (ADF). With nine exceptions all of the proposed flats would receive sufficient levels of daylight.

- 10.145 Those rooms which fall below the BRE Guidelines are predominantly proposed to either be in kitchen use or incorporate a kitchen where higher ADF values are recommended. These rooms either receive high levels of VSC, have a dual aspect or lead directly onto a well-lit living area, which is noted as being appropriate for a non-lit internal kitchen in the BRE Guidelines or have a combination of these factors, such that they would maintain a good level of daylight.
- 10.146 Amenity Space: Policy DM3.5 of the Development Management Policies identifies that 'all new residential development will be required to provide good quality private outdoor space in the form of gardens, balconies, roof terraces and/or glazed ventilated winter gardens'. The policy goes on to state that the minimum requirement for private outdoor space is 5 square metres on upper floors and 15 square metres on ground floor for 1-2 person dwellings. For each additional occupant, an extra 1 square metre is required on upper floors and 5 square metres on ground floor level with a minimum of 30 square metres for family housing (defined as 3 bed units and above).
- 10.147 All of the proposed units are provided with private amenity space in various forms and the proposal includes an uplift in the quantity of publicly available amenity space. Notwithstanding this, three units in Block A and three units in Block C would provide insufficient external amenity space.
- 10.148 Within Block A three non-family units would fall 0.1 square metres below the required amenity space levels, which is not considered to be objectionable in this case.
- 10.149 The three units proposed within Block C are family units and would provide between 23.3 and 27.7 square metres of amenity space. Whilst this is below the required 30 square metres, the proposal includes the provision of two amenity spaces set across ground and first floor level, maximising the extent of useable space within the proposal. By reason of this and the proximity of the affected units to the proposed publicly accessible amenity space, the shortfall in private amenity space provision is considered to be acceptable, with a balance being struck between private amenity space for few against public amenity space increases for all.
- 10.150 Overlooking/Privacy: Two north facing windows in Block A would face into habitable rooms at Block C, while the balconies on this elevation would face directly onto those at Block C. A condition (Condition 9) is proposed relating to obscure glazing and balcony screens to protect future residential amenity.
- 10.151 A second and third floor window in the south elevation of Vickery Court would be located within 18 metres of three first floor windows in Block B. As previously set out, the height change between the proposed and neighbouring windows would ensure that any views into the proposed units would be restricted to the lowermost part of the windows, such that it would not result in unacceptable overlooking. The layout of all other residential units and window placement effectively ensures that there would not be undue overlooking between proposed residential units.
- 10.152 Air Quality: This is an area of poor air quality and as such mechanical ventilation would be required. A condition is recommended requiring the submission of a scheme of ventilation to mitigate the air quality (Condition 32).
- 10.153 Noise: This area is subject to high noise levels from Old Street and therefore conditions are recommended requiring all residential units to include sufficient sound insulation to meet British Standards (Condition 29), sufficient sound insulation is to be provided between the residential units and the A1/A2 and community centre uses (Condition 30). The proposed balconies on Block A that would front Old Street, where noise exposure is at its highest, are proposed to be

Winter Gardens with sliding frameless glass panels in accordance with the submitted Environmental Noise Planning Assessment. A further condition is recommended relating to noise from any proposal plant machinery (Condition 31).

- 10.154 Refuse: Dedicated refuse and recycling facilities/chambers are provided for the residential, commercial and community centre uses. The location and capacity, and management of these facilities have been assessed by the Council's Street Environment Department and are acceptable.
- 10.155 Play Space: Policy DM3.6 of the Development Management Policies requires all major residential development to make provision for play, based on anticipated child yield. Provision shall be 5 square metres of private/informal play space per child (including semi-private outdoor space, private outdoor space and gardens suitable for play).
- 10.156 At present the site incorporates one disused/dilapidated play area set within a gated open space, while there is also limited access to the open spaces across the estate.
- 10.157 The site is located in close proximity (within 400 metres distance) to a number of formal and informal play spaces that cater for all ages, these include facilities at the Pleydell Estate, St. Luke's Estate, Stafford Cripps Estate, open space at St. Luke's Church Gardens, and Radnor Street Open Space and an adventure playground at Toffee Park.
- 10.158 The anticipated child yield for the proposal would require the provision of 196.9 square metres of play space. Over 50% of the anticipated child yield at the estate would be comprised of 0-4 year olds. The proposal includes the provision of 187 square metres of incidental play space for 0-5 year olds set along the main east to west route through the estate. This includes smooth animal sculptures, stepping stones, raised edges, surface patterning, inlaid lettering and art work. In addition to this, 80 square metres of play space would be provided to the rear of the proposed community centre and the ground floor units provide private garden space for play.
- 10.159 Although there is no on-site provision of play space for 5-11 year olds or 12 year olds and above, there is ample provision for this within close proximity to the site (see above). Whilst it is noted that the Design Review Panel questioned the quality of the play space proposed, the site restrictions result in limited space for the provision of dedicated play equipment, which is reflected in the Finsbury Local Plan, which details that informal play should be incorporated in shared space. The proposed play space would provide incidental play of a good quality spread across the estate, with additional play space provided within private gardens and the community centre amenity space. When considered in the context of wider local provision of play space this is considered to provide an adequate level of play space at the site. (Condition 13 Secures this details).
- 10.160 With regard to the maintenance and management of the play space, as this is formed of incidental play set into the pedestrian areas and does not include specific play equipment, it would be maintained as part of the pedestrian areas and landscaping within the estate. As such, a Play Space Management and Maintenance Plan is not necessary. The management and maintenance of the play space to the rear of the community centre would form part of the Community Management Plan (Condition 17).

Dwelling Mix

10.161 The scheme proposes a total of 55 residential units with an overall mix comprised of:

| Dwelling Type | Social Rent (No. units / %) | Policy DM3.1 Target Mix | Private (No. units / %) | Policy DM3.1 Target Mix |
|----------------------|-----------------------------|-------------------------|-------------------------|-------------------------|
| One Bedroom | 11 / 28.2% | 0% | 5 / 31.3% | 10% |
| Two Bedroom | 20 / 51.3% | 20% | 11 / 68.7% | 75% |
| Three Bedroom | 8 / 20.5% | 30% | 0 / 0 % | 15% |
| Four Bedroom or more | 0 / 0% | 50% | 0 / 0% | 0% |
| TOTAL | 39 | 100% | 16 | 100% |

10.162 Part E of policy CS12 of the Islington Core Strategy requires a range of unit sizes within each housing proposal to meet the needs in the borough, including maximising the proportion of family accommodation in both affordable and market housing. In the consideration of housing mix, regard has to be given to the constraints and locality of the site and the characteristics of the development as identified in policy DM3.1 of the Development Management Policies and Site Allocation (BC18) of the Finsbury Local Plan.

10.163 The social rent dwelling mix, when compared to the target social rent dwelling mix departs in as much as an over provision of 1 bedroom and 2 bedroom units and an under provision of large family units. The private dwelling mix has an over provision of 1 bedroom units, a generally acceptable level of 2 bedroom units and no family units.

10.164 The supporting text of policy DM3.1 within Development Management Policies relates to this objective stating 'There may be proposals for affordable housing schemes that are being developed to address short term changes in need/demand as a result of specific interventions (for example, efforts to reduce under-occupation). In these situations deviation from the required policy housing size mix may be acceptable. In such cases registered providers will need to satisfy the council that the proposed housing size mix will address a specific affordable housing need/demand and result in an overall improvement in the utilisation of affordable housing units in Islington'.

10.165 Since the adoption of policy DM3.1, which was informed by Islington's *Local Housing Needs Assessment* (2008) changes to housing legislation (the Welfare Reform Act 2012) to address the under occupation of social housing have created a greater demand for smaller social housing units. This is reflected by the higher proportion of 1 and 2 bedroom units proposed. The applicant, LBI Housing proposes this dwelling mix to allow mobility within the social housing sector to accommodate these national changes to the welfare system. The provision of smaller units will allow for mobility within the estate and the borough which would help to address under occupation.

Affordable Housing and Financial Viability

- 10.166 The London Plan, under policy 3.11 identifies that boroughs within their LDF preparation should set an overall target for the amount of affordable housing provision needed over the plan period in their area and separate targets for social rented and intermediate housing and reflect the strategic priority accorded to the provision of affordable family housing. Point f) of this policy identifies that in setting affordable housing targets, the borough should take account of “*the viability of future development taking into account future resources as far as possible.*”
- 10.167 Policy CS12 of the Islington Core Strategy sets out the policy approach to affordable housing. Policy CS12G establishes that “*50% of additional housing to be built in the borough over the plan period should be affordable and that provision of affordable housing will be sought through sources such as 100% affordable housing scheme by Registered Social Landlords and building affordable housing on Council own land.*” With an understanding of the financial matters that in part underpin development, the policy states that the Council will seek the “*maximum reasonable amount of affordable housing, especially social rented housing, taking into account the overall borough wide strategic target. It is expected that many sites will deliver **at least** 50% of units as affordable subject to a financial viability assessment the availability of public subsidy and individual circumstances on the site.*”
- 10.168 Policy CS12 confirms that an affordable housing tenure split of 70% social rent housing and 30% intermediate housing should be provided.
- 10.169 LB Islington Housing New Build Programme: The proposal forms part of a wider LB Islington Housing New Build programme to provide affordable housing to meet identified needs within the borough. The current programme includes 33 schemes across the borough at various stages of progress (including on-site, pre-contract, pre-planning & feasibility/design) with the aim of delivering 500 new affordable social rented units within the borough by 2019. The programme factors in Right to Buy receipts, S106, GLA grant and recycles returns from the sale of private sale units back into the programme. This then informs the amount of HRA subsidy required to balance the financing of the programme. In the case of Major schemes (those proposing over 10 residential units) these often require significant HRA subsidy to address the shortfall between any revenues generated by the development (which are reinvested into the programme) and the costs of providing it. However, the wider programme currently enables Minor schemes (those proposing less than 10 residential units) to provide 100% affordable housing. All Major proposals forming part of the programme achieve an affordable housing level of well over 50%, which together with the Minor schemes in the programme helps to deliver the Planning Policy target of 50% of additional housing within the borough being affordable.
- 10.170 The Affordable Housing Offer: The proposed development would provide a total of 55 residential units (both for private sale and affordable housing). Of the 55 units (183 habitable rooms, hr), 39 of these units (140 hr) would comprise affordable housing (social rent tenure). The scheme provides 70.9% affordable housing if measured by units and 76.5% affordable housing by habitable rooms.
- 10.171 Within affordable housing provision there is a policy requirement for 70% of provision to be social rent and 30% as intermediate/shared ownership. Although the proposal does not include any intermediate housing, a higher percentage provision of social rent tenure is not considered to be of concern given the identified significant housing needs for this type of accommodation and the emphasis of the policy for the provision of social rented housing. Additionally there remain affordability concerns with respect of shared ownership tenures, particularly in the south of the borough. The Council will have 100% nomination rights in perpetuity on the proposed Social Rented units and these will be let through the local lettings policy.

- 10.172 The proposal fails to provide 100% affordable housing as sought by policy CS12 for developments on Council's own land. The proposed mix includes private housing to financially support the delivery of the affordable housing element, the estate wide public realm improvement works, the re-provision of the Vibast Community Centre and retail units, and the relocation of Spectrum Youth Project and an on-site dentist.
- 10.173 Viability Review: In accordance with policy requirements, a financial viability assessment has been submitted with the application to justify the proportion of affordable housing offered. In order to properly and thoroughly assess the financial viability assessment, the documents were passed to an independent assessor (BPS) to scrutinise and review.
- 10.174 The applicant's Viability Assessment identified that the development as proposed is unviable in a purely commercial sense as it still requires an amount of public subsidy to address the shortfall between the revenues generated by the development and the costs of providing it. Of note is the reference in the BPS Report to a Developer's Return. This does not relate to profit, but is intended to provide a comparison with a private development, with any returns forming part the overall costing of the scheme. BPS has considered the information submitted and has advised that the scheme would be unviable without such a subsidy. The BPS Report is attached at Appendix 4.
- 10.175 In conclusion it is apparent that in a typical commercial sense, the proposed scheme and level of affordable housing is unviable. However the applicant, LBI Housing is not a commercial developer and in line with Council corporate objectives, is primarily seeking to deliver affordable housing, public realm improvements and the re-provision of non-residential uses to meet identified needs such as the relocation of the youth project centre and dentist to 69-85 Old Street, the costs of which are included in the applicant's Viability Assessment.
- 10.176 Though Core Strategy Policy CS12 seeks 100% affordable housing schemes from development on Council land, it is not considered that a failure to provide 100% affordable housing on Council owned land is contrary to that policy where it is shown that considerable public subsidy is required to support the lower provision. In this case, it is not considered that it would be reasonable to require (in planning terms) an additional amount of public subsidy/grant funding to be committed to this scheme to provide a 100% affordable scheme. This offer provides for an element of mix of tenures to be added into this existing estate.
- 10.177 The proposal provides good quality affordable housing, estate-wide improvements and the re-provision of social infrastructure and retail units. In this context, the offer of 70.9% affordable housing (by units) is considered to deliver a good mix of tenures and as supported by a financial viability assessment is considered the maximum reasonable amount of affordable housing and thus is considered to accord with policy. This provision is secured with a Directors Level Agreement.

Sustainability Energy Efficiency and Renewable Energy

- 10.178 The London Plan (2015) Policy 5.1 stipulates a London-wide reduction of carbon emissions of 60 per cent by 2025. Policy 5.2 of the plan requires all development proposals to contribute towards climate change mitigation by minimising carbon dioxide emissions through energy efficient design, the use of less energy and the incorporation of renewable energy. London Plan Policy 5.5 sets strategic targets for new developments to connect to localised and decentralised energy systems while Policy 5.6 requires developments to evaluate the feasibility of Combined Heat and Power (CHP) systems.
- 10.179 All development is required to demonstrate that it has minimised onsite carbon dioxide emissions by maximising energy efficiency, supplying energy efficiently and using onsite renewable energy generation (CS10). Developments should achieve a total (regulated and unregulated) CO2 emissions reduction of at least 27% relative to total emissions from a

building which complies with Building Regulations 2013 (39% where connection to a Decentralised Heating Network is possible). Typically all remaining CO2 emissions should be offset through a financial contribution towards measures which reduce CO2 emissions from the existing building stock (CS10).

- 10.180 The Core Strategy also requires developments to address a number of other sustainability criteria such as climate change adaptation, sustainable transport, sustainable construction and the enhancement of biodiversity. Development Management Policy DM7.1 requires development proposals to integrate best practice sustainable design standards and states that the council will support the development of renewable energy technologies, subject to meeting wider policy requirements. Details are provided within Islington's Environmental Design SPD, which is underpinned by the Mayor's Sustainable Design and Construction Statement SPG. Development Management Policy DM7.4 requires the achievement of BREEAM 'Excellent' on all non-residential major developments. Major developments are also required to comply with Islington's Code of Practice for Construction Sites and to achieve relevant water efficiency targets as set out in the BREEAM standards.
- 10.181 Carbon Emissions: The applicant proposes a reduction in total CO2 emissions of 40.42%, compared to a 2013 Building Regulations baseline. This exceeds the minimum policy requirement and is therefore strongly supported. The development also exceeds the London Plan policy requirement of 35% reduction on regulated emissions, which is again strongly supported. In order to mitigate against the remaining carbon dioxide emissions generated by the development a financial contribution of £96,153 will be secured in the Directors' Agreement.
- 10.182 Efficiency: The proposal would include high performance building fabric, high efficiency heating systems and controls, appropriate air tightness and 100% energy efficient lighting. This would result in highly efficient and well-insulated buildings.
- 10.183 Heating and CHP: The applicant proposes that the development would connect to the Bunhill Energy Network. This is consistent with the London Plan and Islington policy hierarchies, and a connection is strongly supported. Discussions regarding the means of connection are ongoing between the Council's Housing Department, DE team and other relevant parties. This is secured in the Directors' Agreement.
- 10.184 Renewables: The renewables analysis proposes several photovoltaic panel arrays, with a total capacity of 49kWp and covering around 320m² of roof area. This is strongly supported as it maximises the potential of a green sustainable form of energy.
- 10.185 Overheating and Cooling: The energy strategy and overheating analysis do not propose artificial cooling for the flats, and this approach is supported. The overheating modelling and cooling hierarchy is acceptable, and mitigating measures are proposed for the shell and core retail units. However, the noise and air quality strategies may introduce a need for cooling.
- 10.186 Sustainability: The proposed dwellings are detailed to be equivalent to the former Code for Sustainable Homes Level 4, which is in accordance with policy. The community centre and flexible A1/A2 units fall below thresholds for BREEAM assessment. Notwithstanding this, the community centre is detailed to meet a BREEAM rating of Excellent, which is supported.
- 10.187 Green performance Plan: This is secured by the Directors' Agreement.
- 10.188 Sustainable Urban Drainage: A flood risk assessment, including drainage strategy and sustainable urban drainage system has been submitted with the application. This proposes the drainage of surface water to porous paving, blue/green roofs and underground modular storage and has been reviewed and accepted by the Lead Local Flood Authority subject to

maintenances details being approved. The details will be secured by condition (Condition 25) and the responsibility of maintenance placed on the applicant, in this case Islington Housing.

10.189 The energy and sustainability measures proposed are in accordance with policy.

Highways and Transportation

10.190 The site has a Public Transport Accessibility Level (PTAL) of 6a, which is 'Excellent'. The site is located in close vicinity to Old Street and Barbican Train Stations, while there are a number of bus routes within close proximity of the site.

10.191 Public Transport Implications: The development would give rise to additional demands on transport infrastructure in terms of the introduction of residential occupiers and their visitors relative to the existing situation. However, due to the high PTAL level of the site, the proposal would not detrimentally impact upon the surrounding transport infrastructure. A Travel Plan is secured in the Directors' Agreement.

10.192 Vehicle Parking: The estate currently has 61 garaged and 20 surface car parking spaces for residents with a further 21 non-resident parking spaces (around the health centre) and two community centre mini-bus parking spaces. The submitted Transport Assessment details that 35 residential spaces and two community centre mini-bus parking spaces are currently in use. The proposal would result in the overall loss of 64 car parking spaces, re-providing 33 of the spaces currently in use (including the community centre mini-bus parking) with six additional accessible parking spaces serving the wheelchair accessible units and one accessible visitor parking space also proposed. The table below details the type of spaces proposed to be lost and those re-provided, taken from the Transport Assessment:

| | Existing Spaces / (In use) | Proposal | Difference |
|---------------------------------|-----------------------------------|-----------------|-------------------|
| Within Garage | 61 (15) | 31 | - 30 |
| Surface Parking | 41 (20) | 7 | - 34 |
| Community Centre parking | 2 (2) | 2 | 0 |
| Total Parking Spaces | 104 (37) | 40 | - 64 |

10.193 Since the submission of the Transport Assessment and undertaking of the 2013 parking survey, 4 further existing parking spaces have become vacant at the estate, resulting in only 33 existing spaces. However, the amended plans detail the relocation of a substation to the garages and subsequently results in 4 fewer proposed car parking spaces. The proposal would significantly reduce the number of car parking spaces across the estate whilst re-providing all of the parking spaces currently in use by existing residents and providing future wheelchair parking for the new the accessible units.

10.194 Residential occupiers of the new units would not be eligible to attain on-street car parking permits for the surrounding Controlled Parking Zone (CPZ) in the interests of promoting the use of more sustainable forms of transport and tackling congestion and overburdened parking infrastructure, this is secured in the Directors' Agreement. The exceptions to this would be where, in accordance with Council parking policy, future persons occupying the residential development are currently living in residential properties within Islington prior to moving into the development and they have previously held a permit for a period of 12 months consecutive to the date of occupation of the new unit. These residents are able to transfer their existing

permits to their new homes. Residents who are 'blue badge' (disabled parking permit) will also be able to park in the CPZ.

- 10.195 Estate Parking Permits are regulated by Islington's Housing Management Department and allocated on a priority basis. As such, the reallocation of estate parking permits and any future allocation for car parking spaces at the estate would be reviewed internally and only allocated where there was capacity.
- 10.196 A number of motorcycles and mopeds are currently stored within the front area of blocks across the site. Four secure motorcycle parking spaces would be provided within the amended garage space.
- 10.197 Road Safety: The application includes two areas of shared surfaces where pedestrians, cyclists and vehicles have equal priority. These areas would not provide separation between vehicular routes and pedestrian/cycle routes. However, due to their location off main routes, the use of markedly different materials and demarcations within the surface materials, also due to the fact that vehicles entering these areas would be reducing speed to park, it is considered that the shared spaces would provide a safe surface for all users, maximising the efficient layout of the estate.
- 10.198 Delivery and Servicing Arrangements: Policy DM8.6 of the Development Management Policies (2013) requires commercial developments in excess of 200 square metres to provide on-site servicing. While the proposal includes in excess of 200 square metres of flexible retail/professional floor space, this is spread across two smaller units at opposite ends of the estate. As such, this is not considered to be relevant in this case. However, the applicant has detailed that servicing to these units would be from the bus lane on Old Street, outside of restricted times, contrary to policy DM8.6 that seeks to eliminate servicing on bus lanes. This however is no different to the current arrangement and TfL have raised no objections.
- 10.199 While the plans detail the accessible visitor bay to the rear of Block C to also serve as an on-site servicing bay, when in use this would conflict with the use of the bay for accessible parking. Notwithstanding this, the two community centre parking spaces could provide suitable space for on-site servicing. Furthermore, there is potential for on-street servicing from St Luke's Close (to the west) outside of restricted parking hours. As such, a condition is attached (Condition 34) requiring details of servicing arrangements to be submitted prior to the commencement of the relevant uses.
- 10.200 Cycle Parking: The proposal would provide 109 cycle parking spaces, including tricycle and family cycle parking for the new residential units in accordance with the requirements of Appendix 6 of the Development Management Policies 2013. A further 30 individual cycle spaces are proposed to be located across the estate for existing residents to replace the cycle parking lost at the south east corner of the site.
- 10.201 Four cycle parking spaces are provided within the entrance courtyard to the community centre with six publicly accessible cycle parking spaces beyond this and 10 spaces to the east of Block A. This would provide sufficient cycle parking spaces for the community centre and retail/professional services units.
- 10.202 The details of the external bicycle and mobility scooter stores is required by condition (Condition 21).
- 10.203 Waste/Refuse: The proposal includes the provision of refuse stores located within residential cores, bin stores within front gardens and commercial bin stores serving the retail/professional units and community centre. The Council Street Environment Service has been consulted on the proposal and are satisfied that the refuse storage would be acceptable.

- 10.204 Emergency Vehicle Access: Emergency access would remain unchanged from St Luke's Close. Although the vehicular crossover from Bath Street would be relocated 1 metre south, the emergency access would remain unimpeded. Block A would include dry risers and Block B and C would have vehicular access to with 45 metres of every point of the buildings footprint in accordance with part B5 of the Building Regulations.
- 10.205 Construction: The Directors' Agreement ensures the repair and re-instatement of the footways and highways adjoining the development and that the development would be constructed in compliance with the Code of Construction Practice and secures a monitoring fee. Condition 5 secures details of the construction methods to minimise disruption to surrounding streets and residential amenity.

Planning Obligations, Community Infrastructure Levy and local finance considerations

Community Infrastructure Levy:

- 10.206 The Community Infrastructure Levy (CIL) Regulations 2010, part 11 introduced the requirement that planning obligations under section 106 must meet three statutory tests, i.e. that they (i) necessary to make the development acceptable in planning terms, (ii) directly related to the development, and (iii) fairly and reasonably related in scale and kind to the development. Under the terms of the Planning Act 2008 (as amended) and Community Infrastructure Levy Regulations 2010 (as amended), the Mayor of London's and Islington's Community Infrastructure Levy (CIL) will be chargeable on this application on grant of planning permission. This will be calculated in accordance with the Mayor's adopted Community Infrastructure Levy Charging Schedule 2012 and the Islington adopted Community Infrastructure Levy Charging Schedule 2014. The affordable housing is exempt from CIL payments and the payments would be chargeable on implementation of the private housing.

S106:

- 10.207 This is an application by the Council and the Council is the determining local planning authority on the application. It is not possible legally to bind the applicant via a S106 legal agreement. It has been agreed that as an alternative to this a letter and memorandum of understanding between the proper officer representing the applicant LBI Housing and the proper officer as the Local Planning Authority will be agreed subject to any approval. The agreed heads of terms are set out in Appendix 1 to this report. All of those listed obligations are considered to meet the three tests set out above, including the updated requirements restricting the pool of more than five contributions towards a single project.

National Planning Policy Framework

- 10.208 The scheme is considered to accord with the aims of the NPPF and to promote sustainable growth that balances the priorities of economic, social and environmental growth. The NPPF requires local planning authorities to boost significantly the supply of housing and require good design from new development to achieve good planning.

Other Matters

- 10.209 Representations have been received regarding various parts of the development blocking views from neighbouring properties. It should be noted that in respect of planning there is no right to a private view. However, an assessment of sense of enclosure caused by a development is a material consideration (see 'Neighbour Amenity' section).
- 10.210 A number of representations received raise concern regarding disturbance from and the length of time of the construction period. Conditions are recommended which require the submission of a Construction Management Plan to address noise, dust and other environmental

disturbances. The Directors' Agreement ensures that the construction is compliant with the Code of Construction. Outside of planning control there are other controls on construction, such as Environmental Health Regulations that would protect the amenity of neighbouring occupiers during the construction period.

- 10.211 Representations have been received requesting alternative proposals such as an increase in height of Block A, the provision of larger gardens to existing properties and the provision of lifts. It should be noted that it is the role of Development Management to assess a planning application against the relevant adopted planning policies rather than to propose alternatives for the application site. The application has been assessed on the basis of the plans submitted by the applicant.
- 10.212 Concern has been raised in the representations received regarding the uplift in residents at the estate and the ability of infrastructure to cope with this. The proposal would be below minimum density figures for a central London site, the proposal would connect to the Bunhill Energy Network and would be of a sustainable design, while an assessment of the impact of the proposal on Transport infrastructure has found this to be acceptable. With regard to social infrastructure, this is either re-provided as part of the proposal or in the case of the health centre it has been re-provided already. Additionally, the scheme will require payment of a Community Infrastructure Levy on the private residential units and retail units, to be spent on infrastructure projects in the borough.
- 10.213 A number of representations do not consider the proposal to be representative of their views sought by the applicant through the pre-planning consultation. A number of consultations were carried out by the applicant prior to the submission of the planning application. The proposal was amended throughout this process.
- 10.214 Representations have questioned the name of the estate and suggested that this be changed to Redbrick Gardens. The planning process does not include the ability to rename sites.
- 10.215 A representation has been received regarding the cost of the installation of entry phones to leaseholders. However, this is not a material planning consideration.

11 SUMMARY AND CONCLUSION

Summary

- 11.1 A summary of the proposal and its acceptability is provided at paragraphs 4.1 – 4.10 of this report.

Conclusion

- 11.2 It is recommended that planning permission be granted subject to conditions and director level agreement securing the heads of terms for the reasons and details as set out in Appendix 1 – RECOMMENDATIONS.

APPENDIX 1 – RECOMMENDATIONS

RECOMMENDATION A

That planning permission be granted subject to a Directors' Agreement between Housing and Adult Social Services and Environment and Regeneration or Planning and Development in order to secure the following planning obligations to the satisfaction of the Head of Law and Public Services and the Service Director, Planning and Development / Head of Service – Development Management:

- On-site provision of affordable housing in line with submission documents including a provision of 76.5% affordable housing (Social Rent), measured by habitable rooms or 70.9% of affordable housing measured by units.
- The repair and re-instatement of the footways and highways adjoining the development. The cost is to be confirmed by LBI Highways, paid for by the applicant and the work carried out by LBI Highways. Conditions surveys may be required.
- Compliance with the Code of Employment and Training
- Facilitation of 4 work placements during the construction phase of the development, lasting a minimum of 13 weeks, or a fee of £20,000 to be paid to LBI. Developer / contractor to pay wages (must meet national minimum wage). London Borough of Islington Construction Works Team to recruit for and monitor placements.
- Compliance with the Code of Local Procurement.
- Compliance with the Code of Construction Practice, including a monitoring fee of £6260 and submission of a site-specific response document to the Code of Construction Practice for the approval of LBI Public Protection. This shall be submitted prior to any works commencing on site.
- Removal of eligibility for residents' on-street parking permits.
- A contribution towards offsetting any projected residual CO2 emissions of the development, to be charged at the established price per tonne of CO2 for Islington (currently £920); Total amount to be confirmed by the Council's Energy Conservation Officer (£96 153).
- Connection to a local energy network (Bunhill Energy Network), if technically and economically viable (burden of proof will be with the developer to show inability to connect). In the event that a local energy network is not available or connection to it is not economically viable, the developer should develop an on-site solution and/or connect to a neighbouring site (a Shared Heating Network) and future proof any on-site solution so that in all cases (whether or not an on-site solution has been provided), the development can be connected to a local energy network if a viable opportunity arises in the future.
- Prior to the demolition of the existing buildings a Green Performance Plan shall be submitted to and approved by the Local Planning Authority.
- Submission of a draft framework Travel Plan with the planning application, of a draft Travel Plan for Council approval prior to occupation, and of a Travel Plan for Council approval 6 months from first occupation of the development or phase (provision of travel plan required subject to thresholds shown in Table 7.1 of the Planning Obligations SPD).

- Prior to the demolition of 169 – 173 Old Street, London, EC1V 9NJ planning permission ref: P2015/1163/FUL shall be implemented and the replacement dentist and youth project centre operational and open to the public.
- Prevention of wasted housing supply. To require all dwellings to be fully furnished and equipped for use as a home; dwellings not to be left unoccupied for any continuous period of 3 consecutive months or more (plus additional – as per the wording in the Wasted Housing Supply SPD). The applicant agrees to include obligations in sales and marketing information and also agrees to have the s106 requirements written in to any head lease or sublease should they be granted.
- Council’s legal fees in preparing the Directors Agreement and officer’s fees for the preparation, monitoring and implementation of the Directors Agreement.

That, should the Director Level Agreement not be completed prior to the expiry of the planning performance agreement the Service Director, Planning and Development / Head of Service – Development Management may refuse the application on the grounds that the proposed development, in the absence of a Directors’ Level Agreement is not acceptable in planning terms.

RECOMMENDATION B

That the grant of planning permission be subject to **conditions** to secure the following:

List of Conditions:

| | |
|----------|--|
| 1 | Commencement (Compliance) |
| | <p>CONDITION: The development hereby permitted shall be begun not later than the expiration of three years from the date of this permission.</p> <p>REASON: To comply with the provisions of Section 91(1)(a) of the Town and Country Planning Act 1990 as amended by the Planning and Compulsory Purchase Act 2004 (Chapter 5).</p> |
| 2 | Approved plans list (Compliance) |
| | <p>CONDITION: The development hereby approved shall be carried out in accordance with the following approved plans:</p> <p>Planning Statement (LBI-RED-01), Design and Access Statement (dated February 2015), Daylight, Sunlight and Overshadowing Report (Dated 10th February 2015), Email dated 27th May 2015 (additional daylight/sunlight information), Email dated 20th July 2015 (additional daylight/sunlight information) Heritage Statement (dated 15th December 2015), JMP Draft Full Travel Plan Report, JMP Transport Assessment Report, Arboricultural Impact Assessment (DFCP 2680), Flood Risk Assessment and Sustainable Drainage Strategy (130546/TG/LM), CSK008 Rev P1, C110 Rev P3, Ecological Appraisal (DFCP 2680), Ecology Report Template (November 2010 Version), Baily Garner External Lighting Assessment, Energy Strategy Report (26456 dated 13th February 2015), Code for Sustainable Homes Pre-Assessment Report (26456 dated 13th January 2015), Community Centre BREEAM 2014 Pre-Assessment (26456 dated 16th December 2014), Retail (Shell and Core) Sustainability Statement (26456 dated 26th November 2014), Overheating Analysis (26456 dated 11th December 2014), M/E 100 Rev P3, Green Performance Plan (26456 dated 2nd December 2014), BREEAM UK New Construction 2014 Ecologists report to BREEM, Historic Environment Assessment (dated August 2014), Statement of Community Involvement (dated 12th March 2015), Environmental Noise Planning Assessment (A786/R01a), Air Quality Assessment (dated 28th November 2014), Baseline Desk Study (G4100/BDS), unexploded Ordnance Desk Study (Version 1.5),</p> |

| | |
|----------|---|
| | <p>Revised Planning Information (ref: J:3072/5.1_20150728/SL), 3072-D-001 P2, 3072-D-002 P2, 3072-D-002.1 P1, 3072-D-003 P2, 3072-D-004 P1, 3072-D-005 P1, 3072-D-006 P1, 3072-D-007 P1, 3072-D-008 P1, 3072-D-009 P1, 3072-D-010 P1, 3072-D-011 P1, 3072-D-101 P4, 3072-D-102 P3, 3072-D-103 P1, 3072-D-104 P1, 3072-D-105 P1, 3072-D-106 P1, 3072-D-110 P3, 3072-D-111 P3, 3072-D-112 P3, 3072-D-113 P3, 3072-D-114 P3, 3072-D-115 P3, 3072-D-116 P3, 3072-D-117 P3, 3072-D-118 P3, 3072-D-119 P3, 3072-D-121 P3, 3072-D-122 P4, 3072-D-123 P3, 3072-D-124 P3, 3072-D-125 P3, 3072-D-126 P3, 3072-D-127 P3, 3072-D-128 P3, 3072-D-129 P3, 3072-D-130 P2, 3072-D-140 P3, 3072-D-141 P3, 3072-D-142 P3, 3072-D-143 P3, 3072-D-150 P5, 3072-D-151 P3, 3072-D-201 P4, 3072-D-202 P4, 3072-D-203 P4, 3072-D-204 P4, 3072-D-205 P5, 3072-D-206 P6, 3072-D-207 P3, 3072-D-208 P1, 3072-D-700 P3, 3072-D-701 P3, 3072-D-702 P3, 3072-D-703 P3, 3072-D-704 P3, 3072-D-705 P3, 3072-D-706 P3, 3072-D-707 P3, 3072-D-708 P3, 3072-D-709 P3, 3072-D-710 P2, 3072-D-711 P2, 3072-D-712 P4, 3072-D-713 P4, 3072-D-714 P4, 3072-D-715 P3, 3072-D-716 P3, 3072-D-717 P4, 3072-D-718 P3, 3072-D-719 P3, 3072-D-720 P3, 3072-D-721 P3, 3072-D-722 P3, 3072-D-723 P3, 3072-D-724 P3, 3072-D-725 P3, 3072-D-726 P3, 3072-D-727 P2, 3072-D-728 P1, 3072-D-729 P2, 3072-D-730 P1, 3072_L_900 P3, 3072_L_901 P2, 3072_L_902 P2, 3072_L_903 P2, 3072_L_904 P2, 3072_L_905 P2, 3072_L_906 P3, 3072_L_907 P2, 3072_L_908 P2, 3072_L_909 P3, 3072_L_910 P5, 3072_L_911 P1, 3072_L_913 P1, 3072_L_914 P2, 3072_L_915 P1, 3072_L_916 P1 and 3072_L_917 P3.</p> <p>REASON: To comply with Section 70(1)(a) of the Town and Country Act 1990 as amended and the Reason for Grant and also for the avoidance of doubt and in the interest of proper planning.</p> |
| 3 | Phasing (Details) |
| | <p>CONDITION: Prior to the commencement of any part of the development a phasing plan shall be submitted to and approved in writing by the Local Planning Authority. The development shall henceforth not proceed other than in complete accordance with such Plan as will have been approved from time to time by the Local Planning Authority</p> <p>The development shall be carried out strictly in accordance with the details so approved and shall be maintained as such thereafter.</p> <p>REASON: To limit adverse impacts upon the amenities of neighbouring residential properties, and to ensure that the development is implemented to the satisfaction of the Local Planning Authority</p> |
| 4 | Materials and Samples (Compliance and Details) |
| | <p>CONDITION: The facing brickwork to Block A, B and C shall only be constructed from Wienerberger Orange Grove Multi Stock, Wienerberger Broadway Dark Multi and IBSTOCK Platinum White bricks unless otherwise approved in writing by the Local Planning Authority.</p> <p>With the exception of the bricks set out above, details and samples of the following facing materials shall be submitted to and approved in writing by the Local Planning Authority prior to any superstructure work of the relevant phase commencing on site. The details and samples shall include:</p> <p>a) Sample panels of the facing brickwork, as detailed above, showing the colour, texture, pointing and textural brickwork including the boundary walls shall be provided on site;</p> <p>b) window reveals, soldier courses, balconies and shadow gaps;</p> |

| | |
|----------|--|
| | <p>c) Zinc cladding; c) Metal sheet cladding including perforated pattern; d) Roof capping; e) Doors; timber doors and aluminium entrances/screens; f) Aluminium/timber composite window treatment; g) Canopies; h) Balustrades; i) Balcony materials (including winter gardens); j) Roofing materials; k) Green procurement plan; and l) Any other materials to be used.</p> <p>The development shall be carried out strictly in accordance with the details so approved and shall be maintained as such thereafter.</p> <p>REASON: In the interest of securing sustainable development and to ensure that the resulting appearance and construction of the development is of a high standard</p> |
| 5 | <p>Demolition and Construction Management Plan and Demolition and Construction Logistics Plan (Details)</p> |
| | <p>CONDITION: No demolition shall take place unless and until a Demolition and Construction Management Plan (DCMP) and a Demolition and Construction Logistics Plan (DCLP) have been submitted to and approved in writing by the Local Planning Authority.</p> <p>The reports shall assess the impacts during the construction phase of the development on surrounding streets, along with nearby residential amenity and other occupiers together with means of mitigating any identified impacts.</p> <p>The development shall be carried out strictly in accordance with the approved DCMP and DCLP throughout the construction period.</p> <p>REASON: In the interests of residential amenity, highway safety, and the free flow of traffic on streets, and to mitigate the impacts of the development.</p> |
| 6 | <p>Site Waste Management Plan (Details)</p> |
| | <p>CONDITION: Full particulars and details of a Site Waste Management Plan (SWMP) which ensures waste produced from any demolition and construction works is minimised shall be submitted to and approved in writing by the local planning authority before the development hereby permitted is commenced and the development shall not be carried out otherwise than in accordance with the particulars so approved.</p> <p>The SWMP shall identify the volume and type of material to be demolished and or excavated and include an assessment of the feasibility of reuse of any demolition material in the development. The SWMP shall also consider the feasibility of waste and materials transfer to and from the site by water or rail transport wherever that is practicable.</p> <p>REASON: To maximise resource efficiency and minimise the volume of waste produced, in the interest of sustainable development.</p> |
| 7 | <p>Archaeology (Details)</p> |
| | <p>CONDITION: No development other than demolition to existing ground level shall take place until the applicant (or their heirs and successors in title) has secured the implementation of a programme of archaeological evaluation in accordance with a</p> |

| | |
|---|--|
| | <p>written scheme which has been submitted by the applicant and approved by the Local Planning Authority in writing and a report on that evaluation has been submitted to the local planning authority.</p> <p>If heritage assets of archaeological interest are identified by the, then before development, other than demolition to existing ground level, commences the applicant (or their heirs and successors in title) shall secure the implementation of a programme of archaeological investigation in accordance with a Written Scheme of Investigation which has been submitted by the applicant and approved by the Local Planning Authority in writing.</p> <p>No development or demolition shall take place other than in accordance with the approved Written Scheme of Investigation.</p> <p>The development shall not be occupied until the site investigation and post investigation assessment has been completed in accordance with the programme set out in the approved Written Scheme of Investigation, and the provision for analysis, publication and dissemination of the results and archive deposition has been secured.</p> <p>REASON: Heritage assets of archaeological interest may survive on the site. The Local Planning Authority wishes to secure the provision of appropriate archaeological investigation, including the publication of results.</p> |
| 8 | <p>Gates and Open Space (Compliance)</p> |
| | <p>CONDITION: Notwithstanding the plans and documents hereby approved, the two pedestrian gates onto Old Street shall be fixed open and shall not be closed at any time. The gate to the north of Steadman Court serving the new amenity space shall not be locked at any time.</p> <p>REASON: To ensure that the site is accessible and inclusive at all times.</p> |
| 9 | <p>Obscure Glazing and Privacy Screens (Details and Compliance)</p> |
| | <p>CONDITION: Prior to the occupation of the relevant units set out below, details of privacy screens for the following balconies/roof terraces shall be submitted to and approved in writing by the Local Planning Authority:</p> <ul style="list-style-type: none"> - East and part of north end of second floor roof terrace serving Units 40 and 41 in Block B; - East end of second floor roof terrace serving Unit 42 in Block B; and - South end of roof terrace and balconies serving Unit 49, 52 and 55 in Block C. <p>And notwithstanding the approved plans, the following windows shall only be obscurely glazed:</p> <ul style="list-style-type: none"> - The second and third floor north facing kitchen windows serving Unit 10 and 15 in Block A; and - The three third floor west facing windows serving Unit 11 in Block A shall only be obscurely glazed up to half the height of the window; <p>The privacy screens and obscure glazing shall be installed prior to the occupation of the relevant units and retained as such permanently thereafter.</p> <p>REASON: In the interest of preventing undue overlooking between habitable rooms within the development itself, to protect the future amenity and privacy of residents.</p> |

| | |
|-----------|---|
| | |
| 10 | Piling Method Statement (Details) |
| | <p>CONDITION: No impact piling shall take place until a piling method statement (detailing the type of piling to be undertaken and the methodology by which such piling will be carried out, including measures to prevent and minimise the potential for damage to subsurface sewerage infrastructure, and the programme for the works) has been submitted to and approved in writing by the local planning authority in consultation with Thames Water. Any piling must be undertaken in accordance with the terms of the approved piling method statement.</p> <p>REASON: The proposed works will be in close proximity to underground sewerage utility infrastructure. Piling has the potential to impact on local underground sewerage utility infrastructure.</p> |
| 11 | Tree Protection (Details) |
| | <p>CONDITION: No site clearance, preparatory work or development shall take place until a scheme for the appropriate working methods (the Arboricultural Method Statement, AMS) in accordance with British Standard BS 5837 2012 –Trees in Relation to Demolition, Design and Construction has been submitted to and approved in writing by the local planning authority.</p> <p>Development shall be carried out in accordance with the approved AMS.</p> <p>REASON: In the interest of biodiversity, sustainability, and to ensure that a satisfactory standard of visual amenity is provided and maintained.</p> |
| 12 | Site Supervision (Details) |
| | <p>CONDITION: No works or development shall take place until a scheme of supervision and monitoring for the arboricultural protection measures in accordance with para. 6.3 of British Standard BS5837: 2012 – Trees in Relation to design, demolition and construction – recommendations has been approved in writing by the local planning authority.</p> <p>The scheme of supervision shall be carried out as approved and will be administered by a qualified Arboriculturist instructed by the applicant. This scheme will be appropriate to the scale and duration of the works and will include details of:</p> <p>A: Prior to Commencement:</p> <ol style="list-style-type: none"> a. Induction and personnel awareness of arboricultural matters; b. Identification of individual responsibilities and key personnel; c. Statement of delegated powers; d. Timing and methods of site visiting and record keeping, including updates e. Procedures for dealing with variations and incidents. <p>B: Prior to Completion of Development:</p> <p>This tree condition may only be fully discharged on completion of the development subject to satisfactory written evidence of contemporaneous monitoring and compliance by the pre-appointed tree specialist during construction.</p> <p>REASON: In the interest of protecting retained and proposed tree health, biodiversity, sustainability, and to ensure that a satisfactory standard of visual amenity is provided and maintained.</p> |

| | |
|-----------|--|
| 13 | Landscaping/Tree Planting/Play Space (Details) |
| | <p>CONDITION: A landscaping scheme shall be submitted to and approved in writing by the Local Planning Authority prior to superstructure works commencing on site. The landscaping scheme shall include the following details:</p> <ul style="list-style-type: none"> a) existing and proposed underground services and their relationship to both hard and soft landscaping; b) proposed trees: their location, species, size at planting and tree pit detail; c) soft plantings: including grass and turf areas, shrub and herbaceous areas; d) topographical survey: including earthworks, ground finishes, top soiling with both conserved and imported topsoil(s), levels, drainage and fall in drain types; e) enclosures: including types, dimensions and treatments of walls, fences, screen walls, barriers, rails, retaining walls, hedges and the feature metal gate to the community centre; f) hard landscaping: including ground surfaces, kerbs, edges, ridge and flexible pavings, unit paving, furniture, steps and if applicable synthetic surfaces; and g) all playspace equipment and structures; h) scaled elevations of all gateway structures to the estate; and i) any other landscaping feature(s) forming part of the scheme. <p>All landscaping in accordance with the approved scheme shall be completed / planted during the first planting season following practical completion of the development hereby approved. The landscaping and tree planting shall have a two year maintenance / watering provision following planting and any existing tree shown to be retained or trees or shrubs to be planted as part of the approved landscaping scheme which are removed, die, become severely damaged or diseased within five years of completion of the development shall be replaced with the same species or an approved alternative to the satisfaction of the Local Planning Authority within the next planting season.</p> <p>The development shall be carried out strictly in accordance with the details so approved and shall be maintained as such thereafter.</p> <p>REASON: In the interest of biodiversity, sustainability, and to ensure that a satisfactory standard of visual amenity is provided and maintained.</p> |
| 14 | Lighting Plan (Details) |
| | <p>CONDITON: Full details of the lighting across the site shall be submitted to and approved in writing by the Local Planning Authority prior to the commencement of the approved development.</p> <p>The details shall include the location and full specification of: all lamps; light levels/spill lamps, floodlights, support structures, hours of operation and technical details on how impacts on bat foraging will be minised. The lighting measures shall be carried out strictly in accordance with the details so approved, shall be installed prior to occupation of the development and shall be maintained as such thereafter.</p> <p>REASON: To ensure that any resulting general or security lighting is appropriately located, designed do not adversely impact neighbouring residential amenity and are appropriate to the overall design of the buildings as well as protecting the biodiversity value of the site.</p> |
| 15 | Land Use (Compliance) |
| | <p>CONDITION: Notwithstanding the provision of the Town and Country Planning (General Permitted Development) Order 2015 (or any amended/updated subsequent Order) no change of use under Schedule 2, Part 3 of the above Order shall be</p> |

| | |
|-----------|---|
| | <p>carried out to the two flexible retail/professional services units (A1/A2 use class) or community centre (D1 use class) hereby approved without express planning permission.</p> <p>REASON: To ensure that the Local Planning Authority has control over the use of the units within the Central Activities Zone.</p> |
| 16 | Hours of Operation (Compliance) |
| | <p>CONDITION: The two flexible retail/professional services units (A1/A2 use class) hereby approved shall not operate except between the hours of 08:00 and 23:00 Monday to Saturday and 10:00 and 20:00 hours on Sundays and Bank Holidays unless otherwise approved in writing by the Local Planning Authority.</p> <p>REASON: In the interests of protecting residential amenity.</p> |
| 17 | Community Centre Management Plan (Details) |
| | <p>CONDITION: Prior to the occupation of the Community Centre hereby approved a Community Centre Management Plan shall be submitted to and approved in writing by the Local Planning Authority.</p> <p>The community centre shall only operate in accordance with the details of the approved document unless otherwise agreed in writing.</p> <p>REASON: To ensure the sustainable management of the Community Centre, in order to suitably mitigate/minimise any possible disturbance to existing and future residential occupiers of the estate.</p> |
| 18 | Accessibility (Compliance) |
| | <p>CONDITION: The residential dwellings hereby approved shall be constructed to the standards for Flexible Homes in Inclusive Design in Islington SPD (2014) and the two flexible retail/professional services units (A1/A2 use class) hereby approved shall be constructed to the standards set out in the Inclusive Design in Islington SPD (2014)</p> <p>REASON: To secure the provision of flexible, visitable and adaptable home appropriate to diverse and changing needs and to ensure the retail units are accessible and inclusive.</p> |
| 19 | Wheelchair Accessible Units (Compliance) |
| | <p>CONDITION: The six (6) wheelchair accessible dwellings of the development as identified in the approved documents shall be provided and fitted out prior to the first occupation of the development.</p> <p>REASON: To secure provision of the appropriate number of wheelchair accessible units in a timely fashion; to address the backlog of and current unmet accommodation needs; produce a sustainable mix of accommodation; and provide appropriate choices and housing opportunities for wheelchair users and their families.</p> |
| 20 | Accessible Car Parking (Compliance) |
| | <p>CONDITION: The seven (7) disabled parking bays hereby approved shall be constructed and available for use by eligible occupants of the wheelchair accessible units approved and existing blue badge holders within the development prior to the first occupation of the relevant part of the development and shall be appropriately line-marked and thereafter kept available for their intended use at all times if and when required.</p> |

| | |
|-----------|--|
| | <p>REASON: To ensure that the design and construction of the disabled parking bays are appropriate and meet with the council's design criteria, furthermore that the new bays are designed to a suitable standard which ensures that they are eligible for adoption.</p> |
| 21 | Cycle and Mobility Scooter Stores and other stores (Details) |
| | <p>CONDITION: Details of the external bicycle and mobility scooter stores and other stores, including plans and elevations, shall be submitted to and approved in writing by the Local Planning Authority. The approved bicycle and mobility scooter stores shall be provided prior to the first occupation of the development hereby approved and shall be maintained as such thereafter.</p> <p>REASON: To ensure adequate cycle parking and mobility scooter storage is available and easily accessible on site, to promote sustainable modes of transport and to secure the high quality design of the structures proposed.</p> |
| 22 | Sustainability (Compliance) |
| | <p>CONDITION: The residential units hereby approved shall achieve the credits detailed in the 'Code for Sustainable Homes Pre-Assessment Report' (Job No. 26456 dated 13th January 2015).</p> <p>REASON: In the interest of addressing climate change and to secure sustainable development.</p> |
| 23 | Solar Photovoltaic Panels (Details) |
| | <p>CONDITION: Prior to the commencement of the development hereby approved, details of the proposed Solar Photovoltaic Panels at the site shall be submitted to and approved in writing by the Local Planning Authority. These details shall include but not be limited to:</p> <ul style="list-style-type: none"> - Location; - Area of panels; and - Design (including elevation plans). <p>The solar photovoltaic panels as approved shall be installed prior to the first occupation of the development and retained as such permanently thereafter.</p> <p>REASON: In the interest of addressing climate change and to secure sustainable development and to secure high quality design in the resultant development.</p> |
| 24 | Green/Brown/Blue Biodiversity Roofs (Details) |
| | <p>CONDITION: Prior to any superstructure work commencing on the development details of the green/brown/blue roofs shown across the development shall be submitted to and approved in writing by the Local Planning Authority</p> <p>The green/brown/blue roofs shall be:</p> <ol style="list-style-type: none"> a) biodiversity based with extensive substrate base (depth 80 -150mm); b) laid out in accordance with plans hereby approved; and c) planted/seeded with a mix of species within the first planting season following the practical completion of the building works (the seed mix shall be focused on wildflower planting, and shall contain no more than a maximum of 25% sedum). <p>The biodiversity (green/brown/blue) roofs should be maximised across the site and shall not be used as an amenity or sitting out space of any kind whatsoever and shall</p> |

| | |
|-----------|--|
| | <p>only be used in the case of essential maintenance or repair, or escape in case of emergency.</p> <p>The biodiversity roof(s) shall be carried out strictly in accordance with the details as approved, shall be laid out within 3 months of next available appropriate planting season after the construction of the building it is located on and shall be maintained as such thereafter.</p> <p>REASON: To ensure the development provides the maximum possible provision towards creation of habitats, valuable areas for biodiversity and minimise run-off.</p> |
| 25 | Sustainable Urban Drainage System (Compliance) |
| | <p>CONDITION: No development shall take place unless and until a detailed implementation, maintenance and management plan of the approved sustainable drainage scheme has been submitted to and approved in writing by the Local Planning Authority. Those details shall include:</p> <ol style="list-style-type: none"> I. a timetable for its implementation, and II. a management and maintenance plan for the lifetime of the development which shall include the arrangements for adoption by any public body or statutory undertaker, or any other arrangements to secure the operation of the sustainable drainage scheme throughout its lifetime. <p>No building(s) hereby approved shall be occupied unless and until the approved sustainable drainage scheme for the site has been installed/completed strictly in accordance with the approved details.</p> <p>The scheme shall thereafter be managed and maintained in accordance with the approved details.</p> <p>REASON: To ensure that sustainable management of water and minimise the potential for surface level flooding.</p> |
| 26 | Water Use (Compliance) |
| | <p>CONDITION: The development shall be designed to achieve a water use target of no more than 95 litres per person per day, including by incorporating water efficient fixtures and fittings.</p> <p>REASON: To ensure the sustainable use of water.</p> |
| 27 | Rainwater Butts and Composting (Details) |
| | <p>CONDITION: Details of rainwater butts and composting facilities shall be submitted to and approved in writing by the Local Planning Authority prior to the first occupation of the development.</p> <p>The details as approved shall be brought into use prior to the first occupation of the development and retained as such permanently thereafter.</p> <p>REASON: To ensure the sustainable use of water and in accordance with sustainability policy.</p> |
| 28 | Energy Efficiency – CO2 Reduction (Compliance/Details) |
| | <p>CONDITION: The energy efficiency measures as outlined within the approved Energy Strategy (Job No. 26456 dated 13th February 2015) which shall together provide for no less than a 40.42% on-site total CO2 reduction in comparison with total</p> |

| | |
|-----------|---|
| | <p>emissions from a building which complies with Building Regulations 2010 as detailed within the Sustainable Design and Construction Statement shall be installed and operational prior to the first occupation of the development.</p> <p>Should there be any change to the energy efficiency measures within the approved Energy Strategy, the following shall be submitted prior to the commencement of the development:</p> <p>A revised Energy Strategy, which shall provide for no less than a 40% onsite total CO2 reduction in comparison with total emissions from a building which complies with Building Regulations 2010. This shall include the details of any strategy needed to mitigate poor air quality (such as mechanical ventilation).</p> <p>The final agreed scheme shall be installed and in operation prior to the first occupation of the development.</p> <p>The development shall be carried out strictly in accordance with the details so approved and shall be maintained as such thereafter.</p> <p>REASON: In the interest of addressing climate change and to secure sustainable development.</p> |
| 29 | Sound Insulation (Compliance) |
| | <p>CONDITION: For all the approved residential units sound insulation and noise control measures shall be used to achieve the following internal noise targets (in line with BS 8233:2014):</p> <p>Bedrooms (23.00-07.00 hrs) 30 dB Laeq,8 hour and 45 dB Lmax (fast) Living Rooms (07.00-23.00 hrs) 35 dB Laeq, 16 hour Dining rooms (07.00 –23.00 hrs) 40 dB Laeq, 16 hour</p> <p>The sound insulation and noise control measures shall be implemented prior to the first occupation of the relevant phase of the development hereby approved, shall be maintained as such thereafter and no change therefrom shall take place without the prior written consent of the Local Planning Authority.</p> <p>REASON: To ensure that an appropriate standard of residential accommodation is provided in terms of external road noise and noise transfer between commercial/community uses and residential uses.</p> |
| 30 | Community Centre and Flexible Retail/Professional Services Sound Insulation (Details) |
| | <p>CONDITION: Full particulars and details of a scheme for sound insulation between the proposed community centre, flexible retail/professional services use and residential use of Blocks A & B shall be submitted to and approved in writing by the Local Planning Authority prior to superstructure works commencing on site.</p> <p>The sound insulation and noise control measures shall be carried out strictly in accordance with the details so approved, shall be implemented prior to the first occupation of the development hereby approved, shall be maintained as such thereafter and no change therefrom shall take place without the prior written consent of the Local Planning Authority</p> <p>REASON: To ensure that an appropriate standard of residential accommodation is provided.</p> |

| | |
|-----------|--|
| 31 | Plant Machinery (Compliance) |
| | <p>CONDITION: The design and installation of new items of fixed plant shall be such that when operating the cumulative noise level LAeq Tr arising from the proposed plant, measured or predicted at 1m from the facade of the nearest noise sensitive premises, shall be a rating level of at least 5dB(A) below the background noise level LAF90 Tbg. The measurement and/or prediction of the noise should be carried out in accordance with the methodology contained within BS 4142: 2014. This shall include noise from any strategy adopted to mitigate poor air quality.</p> <p>REASON: To ensure that an appropriate standard of residential accommodation is provided.</p> |
| 32 | Air Quality (Details) |
| | <p>CONDITION: Prior to superstructure works commencing on the development hereby permitted, a site report detailing steps to minimise the development's future occupiers' exposure to air pollution shall be submitted to and approved by the Local Planning Authority. The approved scheme shall be brought into use prior to the first occupation of the relevant part of the development and retained as such permanently thereafter.</p> <p>REASON: To ensure an adequate air quality to residential occupiers.</p> |
| 33 | Nesting Boxes (Details) |
| | <p>CONDITIONS: Details of bird and bat nesting boxes/bricks shall be submitted to and approved in writing by the Local Planning Authority prior to construction works commencing on site.</p> <p>The nesting boxes/bricks shall be provided strictly in accordance with the details so approved, installed prior to the first occupation of the building to which they form part or the first use of the space in which they are contained and shall be maintained as such thereafter.</p> <p>REASON: To ensure the development provides the maximum possible provision towards creation of habitats and valuable areas for biodiversity.</p> |
| 34 | Delivery Servicing Plan (Details) |
| | <p>CONDITION: A delivery and servicing plan (DSP) detailing servicing arrangements for the flexible retail/professional services units and the community centre including the location, times and frequency shall be submitted to and approved in writing by the Local Planning Authority prior to the first occupation of the relevant commercial/community units development hereby approved.</p> <p>The development shall be constructed and operated strictly in accordance with the details so approved, shall be maintained as such thereafter and no change there from shall take place without the prior written consent of the Local Planning Authority.</p> <p>REASON: To ensure that the resulting servicing arrangements are satisfactory in terms of their impact on highway safety and the free-flow of traffic.</p> |
| 35 | No Plumbing or Pipes (Compliance/Details) |
| | <p>CONDITION: Notwithstanding the plans hereby approved, no plumbing, down pipes, rainwater pipes or foul pipes other than those shown on the approved plans shall be located to the external elevations of buildings hereby approved without obtaining express planning consent unless submitted to and approved in writing by the local planning authority as part of discharging this condition.</p> |

| | |
|-----------|--|
| | <p>REASON: The Local Planning Authority considers that such plumbing and pipes would potentially detract from the appearance of the building and undermine the current assessment of the application.</p> |
| 36 | <p>Refuse/Recycling Provided (Compliance)</p> |
| | <p>CONDITION: The dedicated refuse / recycling enclosure(s) shown on the plans hereby approved shall be provided prior to the first occupation of the relevant part of the development and shall be maintained as such thereafter.</p> <p>REASON: To secure the necessary physical waste enclosures to support the development and to ensure that responsible waste management practices are adhered to.</p> |
| 37 | <p>CCTV (Details)</p> |
| | <p>CONDITION: Prior to construction works commencing on site, details of all CCTV locations, including CCTV to the garage building and high level 'combat sockets' to lighting columns for mobile CCTV shall be submitted to and approved in writing by the Local Planning Authority. The approved CCTV shall be installed and brought into use prior to the first occupation of the development.</p> <p>REASON: To ensure adequate safety and security measures at the site and that the CCTV is appropriately located, and is appropriate to the overall design of the building.</p> |

List of Informatives:

| | |
|----------|---|
| 1 | Planning Obligations Agreement |
| | You are advised that this permission has been granted subject to the completion of a director level agreement to secure agreed planning obligations. |
| 2 | Superstructure |
| | <p>DEFINITION OF 'SUPERSTRUCTURE' AND 'PRACTICAL COMPLETION'</p> <p>A number of conditions attached to this permission have the time restrictions 'prior to superstructure works commencing on site' and/or 'following practical completion'. The council considers the definition of 'superstructure' as having its normal or dictionary meaning, which is: the part of a building above its foundations. The council considers the definition of 'practical completion' to be: when the work reaches a state of readiness for use or occupation even though there may be outstanding works/matters to be carried out.</p> |
| 3 | Community Infrastructure Levy (CIL) (Granting Consent) |
| | <p>INFORMATIVE: Under the terms of the Planning Act 2008 (as amended) and Community Infrastructure Levy Regulations 2010 (as amended), this development is liable to pay the Mayor of London's Community Infrastructure Levy (CIL). This will be calculated in accordance with the Mayor of London's CIL Charging Schedule 2012. One of the development parties must now assume liability to pay CIL by submitting an Assumption of Liability Notice to the Council at cil@islington.gov.uk. The Council will then issue a Liability Notice setting out the amount of CIL that is payable.</p> <p>Failure to submit a valid Assumption of Liability Notice and Commencement Notice prior to commencement of the development may result in surcharges being imposed. The above forms can be found on the planning portal at: www.planningportal.gov.uk/planning/applications/howtoapply/whattosubmit/cil</p> |
| 4 | Car-Free Development |
| | <p>INFORMATIVE: (Car-Free Development) All new developments are car free in accordance with Policy CS10 of the Islington Core Strategy 2011. This means that no parking provision will be allowed on site and occupiers will have no ability to obtain car parking permits, except for parking needed to meet the needs of disabled people, or other exemption under the Council Parking Policy Statement.</p> |
| 5 | Water Infrastructure |
| | <p>There is a Thames Water main crossing the development site which may/will need to be diverted at the Developer's cost, or necessitate amendments to the proposed development design so that the aforementioned main can be retained. Unrestricted access must be available at all times for maintenance and repair. Please contact Thames Water Developer Services, Contact Centre on Telephone No: 0845 850 2777 for further information.</p> <p>Thames Water will aim to provide customers with a minimum pressure of 10m head (approx 1 bar) and a flow rate of 9 litres/minute at the point where it leaves Thames Waters pipes. The developer should take account of this minimum pressure in the design of the proposed development.</p> |
| 6 | Working in a Positive and Proactive Way |
| | <p>To assist applicants in a positive manner, the Local Planning Authority has produced policies and written guidance, all of which are available on the Council's website.</p> <p>A pre-application advice service is also offered and encouraged.</p> |

| | |
|-----------|--|
| | <p>The LPA and the applicant have worked positively and proactively in a collaborative manner through both the pre-application and the application stages to deliver an acceptable development in accordance with the requirements of the NPPF</p> <p>The LPA delivered the decision in a timely manner in accordance with the requirements of the NPPF.</p> |
| 7 | Materials |
| | <p>INFORMATIVE: In addition to compliance with condition 4, materials procured for the development should be selected to be sustainably sourced and otherwise minimise their environmental impact, including through maximisation of recycled content, use of local suppliers and by reference to the BRE's Green Guide Specification.</p> |
| 8 | Window/Balcony Details |
| | <p>INFORMATIVE: The window reveals and balcony details required by condition 4 should be in accordance with the details set out in Section 7.5 of the Design and Access Statement.</p> |
| 9 | Archaeology |
| | <p>Written schemes of investigation will need to be prepared and implemented by a suitably qualified archaeological practice in accordance with Historic England Greater London Archaeology guidelines. They must be approved by the Local Planning Authority before any on-site development related activity occurs.</p> |
| 10 | London Fire and Emergency |
| | <p>It should be noted by the applicant that Block A should include dry risers and the proposal should be laid out in accordance with part B5 of the building regulations.</p> |

APPENDIX 2: RELEVANT POLICIES

This appendix lists all relevant development plan policies and guidance notes pertinent to the determination of this planning application.

National Guidance

The National Planning Policy Framework 2012 seeks to secure positive growth in a way that effectively balances economic, environmental and social progress for this and future generations. The NPPF is a material consideration and has been taken into account as part of the assessment of these proposals.

Development Plan

The Development Plan is comprised of the London Plan 2011, Islington Core Strategy 2011, Development Management Policies 2013, Finsbury Local Plan 2013 and Site Allocations 2013. The following policies of the Development Plan are considered relevant to this application:

A) The London Plan 2015 - Spatial Development Strategy for Greater London

1 Context and strategy

Policy 1.1 Delivering the strategic vision and objectives for London

2 London's places

Policy 2.18 Green infrastructure: the network of open and green spaces

3 London's people

Policy 3.1 Ensuring equal life chances for all

Policy 3.2 Improving health and addressing health inequalities

Policy 3.3 Increasing housing supply

Policy 3.4 Optimising housing potential

Policy 3.5 Quality and design of housing developments

Policy 3.6 Children and young people's play and informal recreation facilities

Policy 3.7 Large residential developments

Policy 3.8 Housing choice

Policy 3.9 Mixed and balanced communities

Policy 3.10 Definition of affordable housing

Policy 3.11 Affordable housing targets

Policy 3.13 Affordable housing thresholds

Policy 3.14 Existing housing

Policy 3.15 Coordination of housing development and investment

Policy 3.16 Protection and enhancement of social infrastructure

5 London's response to climate change

Policy 5.1 Climate change mitigation

Policy 5.2 Minimising carbon dioxide emissions

Policy 5.3 Sustainable design and construction

Policy 5.5 Decentralised energy networks

Policy 5.6 Decentralised energy in development proposals

Policy 5.7 Renewable energy

Policy 5.8 Innovative energy technologies

Policy 5.9 Overheating and cooling

Policy 5.10 Urban greening

Policy 5.11 Green roofs and development site environs

Policy 5.12 Flood risk management

Policy 5.13 Sustainable drainage

Policy 5.14 Water quality and wastewater infrastructure

Policy 5.15 Water use and supplies

Policy 5.16 Waste self-sufficiency

Policy 5.17 Waste capacity

Policy 5.18 Construction, excavation and demolition waste

6 London's transport

Policy 6.1 Strategic approach

Policy 6.2 Providing public transport capacity and safeguarding land for transport

Policy 6.3 Assessing effects of development on transport capacity

Policy 6.4 Enhancing London's transport connectivity

Policy 6.7 Better streets and surface transport

Policy 6.9 Cycling

Policy 6.10 Walking

Policy 6.11 Smoothing traffic flow and tackling congestion

Policy 6.12 Road network capacity

Policy 6.13 Parking

7 London's living places and spaces

Policy 7.1 Building London's neighbourhoods and communities

Policy 7.2 An inclusive environment

Policy 7.3 Designing out crime

Policy 7.4 Local character

Policy 7.5 Public realm

Policy 7.6 Architecture

Policy 7.7 Location and design of tall and large buildings

Policy 7.8 Heritage assets and archaeology

Policy 7.13 Safety, security and resilience to emergency

Policy 7.14 Improving air quality

Policy 7.15 Reducing noise and enhancing soundscapes

Policy 7.19 Biodiversity and access to nature

Policy 7.21 Trees and woodlands

8 Implementation, monitoring and review

Policy 8.1 Implementation

Policy 8.2 Planning obligations

Policy 8.3 Community infrastructure levy

B) Islington Core Strategy 2011

Spatial Strategy

CS7 Bunhill and Clerkenwell

Policy CS13 Employment Spaces

Policy CS14 (Retail and Services)

Policy CS8 (Enhancing Islington's Character)

Strategic Policies

Policy CS9 (Protecting and Enhancing Islington's Built and Historic Environment)
Policy CS10 (Sustainable Design)
Policy CS11 (Waste)
Policy CS12 (Meeting the Housing Challenge)

Policy CS15 (Open Space and Green Infrastructure)

Policy CS16 (Play Space)
Policy CS17 (Sports and Recreation Provision)

Infrastructure and Implementation

Policy CS18 (Delivery and Infrastructure)
Policy CS19 (Health Impact Assessments)

C) Development Management Policies June 2013

Design and Heritage

DM2.1 Design
DM2.2 Inclusive Design
DM2.3 Heritage
DM2.5 Landmarks

Housing

DM3.1 Mix of housing sizes
DM3.2 Existing housing
DM3.4 Housing standards
DM3.5 Private outdoor space
DM3.6 Play space
DM3.7 Noise and vibration (residential uses)

Shops, cultures and services

DM4.1 Maintaining and promoting small and independent shops
DM4.7 Dispersed shops
DM4.8 Shopfronts
DM4.12 Social and strategic infrastructure and cultural facilities

Health and open space

DM6.1 Healthy development
DM6.3 Protecting open space
DM6.4 Sport and recreation
DM6.5 Landscaping, trees and biodiversity
DM6.6 Flood prevention

Health and open space

DM6.1 Healthy development
DM6.3 Protecting open space
DM6.4 Sport and recreation
DM6.5 Landscaping, trees and biodiversity
DM6.6 Flood prevention

Energy and Environmental Standards

DM7.1 Sustainable design and construction statements
DM7.2 Energy efficiency and carbon reduction in minor schemes
DM7.3 Decentralised energy networks
DM7.4 Sustainable design standards
DM7.5 Heating and cooling

Transport

DM8.1 Movement hierarchy
DM8.2 Managing transport impacts
DM8.3 Public transport
DM8.4 Walking and cycling
DM8.5 Vehicle parking
DM8.6 Delivery and servicing for new developments

Infrastructure

DM9.1 Infrastructure
DM9.2 Planning obligations
DM9.3 Implementation

Designations

The site has the following designations under the London Plan 2011, Islington Core Strategy 2011, Development Management Policies 2013, Finsbury Local Plan 2013 and Site Allocations 2013:

- Rail safeguarding Area
- Site of Importance for Nature Conservation (SINC)
- Open Space
- Within 100 metres of Strategic Road Network
- Within 50 metres of Canonbury Conservation

- Area
- Within 50 metres of East Canonbury Conservation Area

Supplementary Planning Guidance (SPG) / Document (SPD)

The following SPGs and/or SPDs are relevant:

Islington Local Plan

- Environmental Design
- Accessible Housing in Islington
- Inclusive Landscape Design
- Planning Obligations and S106
- Urban Design Guide
- Conservation Area Design Guidelines

London Plan

- Accessible London: Achieving and Inclusive Environment
- Housing
- Sustainable Design & Construction
- Providing for Children and Young Peoples Play and Informal Recreation
- Planning for Equality and Diversity in London

APPENDIX 3: DRP Comments

8th July 2014

CONFIDENTIAL

Teresa Santucci
Housing & Adult Social Services
Housing Development and Regeneration
London Borough of Islington
257 Upper Street
N1 1RU



Planning Service
Planning and Development
PO Box 333
222 Upper Street
London
N1 1YA

T 020 7527 2389
F 020 7527 2731
E Luciana.grave@islington.gov.uk
W www.islington.gov.uk

Our ref: **DRP/031**

Date: 4 August 2014

Dear Teresa Santucci,

ISLINGTON DESIGN REVIEW PANEL

RE: Redbrick Estate, Old Street, London, EC1V 9NH

Thank you for coming to Islington's Design Review Panel meeting on 8 July 2014 for review of a proposed development scheme at the above address. The proposed scheme under consideration was for demolition of two storey building and single storey building fronting Old Street and partial demolition of two storey car park building on Bath Street; erection of part single, part four and part nine storey building on the corner of Old Street and Bath Street, comprising a community centre, A1 ground floor use with residential units on the upper floors, erection of part two, part three storey building on corner of Old Street and St. Luke's Close comprising ground floor retail with residential units to the rear and upper floors and erection of four storey building on Bath Street comprising residential units; landscaping to entire estate including creation of a square and extensive planting (officer's description).

Review Process

The Design Review Panel provides expert impartial design advice following the 10 key principles of design review established by Design Council/CABE. The scheme was reviewed by Dominic Papa (Chair), Stafford Critchlow, Stuart Piercy, Stephen Archer, Martin Pearson and Paul Reynolds on Tuesday 8 July 2014 including a site visit in the morning, followed by a presentation by the design team, question and answers session and deliberations in the afternoon at Islington's Laycock Building, Laycock Street. The views expressed below are a reflection of the Panel's discussions as an independent advisory body to the council.

Panel's observations

- **Concept:** The Panel was very welcoming of the idea of improving the estate, in particular the relationship with Old Street and the connectivity with surrounding areas. However, panel members felt that the scheme's true vision was very unclear from the material presented and that the design team's remit was not very legible. It was felt that more clarity was needed in relation to the scope of the proposed works and that, in the long term, the works should be considered in the context of larger ambitions for the estate. Although unfortunately not the remit of the design team, the Panel felt it would be helpful if the scheme was viewed within the context of a wider, potentially long term, masterplan for the estate and not just within the limited confines of the current scope of the architects' brief.

- **Architectural treatment:** The Panel was generally positive about the proposed architectural language for the new blocks, in particular in relation to the Bath Street elevation. Panel members pointed out that Block B lacked the resolution which was seen in relation to Blocks A and C. It was also highlighted that Block C needed improvement in relation to amenity and quality of its frontages and that the design team should consider setting this building back from the street. It was considered that with ground floor single aspect units being very deep, it would be necessary to look at ventilation in particular. Panel members also commented on the design of Block B expressing concerns that it was not clear what the aspect of the units on the tower (Block A) would be when looking onto the top of the community centre. Panel members stressed that roofplans and sections would be helpful to understand this aspect of the design and that long views from Old Street east and west, down Bath Street from the north were important to understand the impact of the overall scheme on surrounding townscape.

- Panel members were concerned about the resolution of the northeast corner where it showed the use of transparent material/glass but it was indicated that there would be a bike store behind. The Panel asked the design team to revisit this area to ensure there would be no harmful impact on the quality of the streetscene.

- **Materiality:** There was some discussion surrounding the choice and quality of materials. Panel members suggested that the design team should think about the estate's evolution and whether it would be more appropriate to reinforce the estate's current separation from everything around it or to gradually break down the 'estates' singularity and create more integration. It was questioned whether the choice of red brick was the right one and panel members generally found that material choices needed to be subtle. The Panel highlighted the importance of the use of high quality of materials and careful consideration of design elements such as deep reveals, texture and detailing.

- **Boundary and permeability:** Although the Panel understood the constraints faced by the design team and the aspirations of local residents, they stressed that they could not support the concept of a gated development as it goes against policy, Council aspirations for permeability and general urban design best practice. Panel members were strongly concerned that there was no consistency of approach with a lack of identity to the boundary treatment solution, and in particular were not convinced with the proposals to break up the high brick wall facing Old Street with planting that 'breaks through' the wall. They were apprehensive that the proposals lacked a clear diagram of permeability, connectivity and circulation. During the presentation, it was indicated to panel members that the main issue in terms of security was generated from Old Street. Therefore, the Panel suggested that attention should be focused to these problem areas.

- **Amenity spaces:** Concerns were raised regarding the character of the estate and its amenity spaces. Panel members were concerned that the proposals indicated a series of quiet spaces with the absence of formal play areas and that those spaces did not seem to compliment each other. They felt that a more holistic approach in relation to the amenity spaces was required. For example, it was indicated that the design of the new square needed to be informed by the use of the other amenity spaces otherwise there would be a risk of long-term implications on the use and quality of those spaces.

Summary

The Panel was generally supportive of the concept of estate regeneration. However, Panel members raised strong concerns in relation to the lack of a more comprehensive masterplan. The Panel also highlighted the need to revisit or further develop some aspects of the scheme such as the boundary treatment and relationship with circulation, permeability and connectivity, the quality of amenity spaces, the proposed materiality and architectural treatment.

Thank you for consulting Islington's Design Review Panel. If there is any point that requires clarification please do not hesitate to contact me and I will be happy to seek further advice from the Panel.

Confidentiality

Please note that since the scheme is at pre-application stage, the advice contained in this letter is provided in confidence. However, should this scheme become the subject of a planning application, the views expressed in this letter may become public and will be taken into account by the council in the assessment of the proposal and determination of the application.

Yours sincerely,

A handwritten signature in black ink, appearing to read 'Lucy', written in a cursive style.**Luciana Grave**

Design Review Panel Coordinator/
Design & Conservation Team Manager

APPENDIX 4: Independent Viability Appraisal (REDACTED)

Redbrick Estate, Islington, EC1V Independent Viability Review



14th April March 2015

Planning application reference: P2015/0709/FUL

1.0 INTRODUCTION

- 1.1 We have been instructed by the Planning & Regeneration Division of the London Borough of Islington to review a viability assessment of a proposed redevelopment of Redbrick Estate. This is a Council-led regeneration scheme, and the applicant is the London Borough of Islington.
- 1.2 Redbrick Estate is a 1960s social housing estate comprised of 4 blocks, Steadman Court, Bartholomew Court, Vickery Court and Cope House. It is located on the north-west side of Old Street, and is bounded by Bath Street to the east and by Mitchel Street to the north.
- 1.3 The proposed scheme will provide 55 new-build residential units (183 habitable rooms), two retail units (flexible A1/A2 Use Class) and one community centre (D1 Use). The housing will consist of 39 Social Rent units, 71% of the total and 16 private market units, to be delivered in three new-build blocks. None of the existing residential units on the site will be demolished, thus the net additional increase in housing is 55 units.
- 1.4 Islington Borough Council's Core Strategy policy C12 sets a strategic target that "50% of additional housing to be built in the borough over the plan period should be affordable", which is a target that applies to the proposed Redbrick Estate scheme.
- 1.5 CS12 sets out the Council's tenure split requirement of 70% social housing and 30% intermediate housing. The applicant is providing 100% of the affordable units as Social Rent tenure, thus is exceeding the 70% target for this tenure.
- 1.6 The applicant's development appraisal of the application scheme includes £105,370 of S106 Contributions, £83,700 of Mayoral CIL payments and £391,166 of Islington CIL payments. We have been advised that these levels of planning obligations have been calculated by Planning Officers.
- 1.7 The applicant has provided a Financial Evaluation report which summarises the results of its development appraisal of the proposed scheme, and discusses some of the appraisal's key cost and value inputs. This report is supported by a Cost Plan prepared by Walker Management and by a Valuation Report prepared by Deloitte.
- 1.8 Our review has sought to scrutinise the methodology and the cost and value assumptions that have been applied in the applicant's development appraisal, in order to evaluate whether the currently proposed level of affordable housing represents the maximum that can viably be delivered.

2.0 CONCLUSIONS & RECOMMENDATIONS

- 2.1 The applicant has undertaken a residual valuation using a methodology that is commonly applied in assessments of viability for planning purposes. We have therefore focussed primarily upon the residual valuation model in our review of viability.
- 2.2 Once our estimate affordable housing values has been applied (totalling £7.9m) the scheme generates a residual value of -£1.26m. This does not factor in a benchmark land value, but does factor in relocation costs of £300,000 for the Dentists and the Spectrum. In this context, it is apparent that the scheme cannot realistically provide a higher proportion of affordable housing than is currently being proposed.
- 2.3 We have considered the cost and value inputs into the residual valuation, and have reached the conclusion that these all appear to be realistic, with the exception of the investment valuation of the affordable housing which appears to overstate their potential capital values. By contrast it appears that the build costs are marginally overstated.
- 2.4 The residual valuation does not include finance costs. Allowing for a typical pre-construction period of 6 months, we have calculated a total finance cost of £1.61m, which would further reduce the scheme's residual value and serve to increase the apparent deficit.
- 2.5 Our Cost Consultant has suggested that build cost reductions totalling £219,000 may be appropriate. This relatively minor adjustment would have a minimal impact overall on the viability position of the scheme, and would not therefore affect our conclusions concerning viability.
- 2.6 As the applicant already owns the site and has done so for a long period, it has not incurred site acquisition costs, thus does not need to fund any site acquisition. In consequence delivering a scheme which generates a minimum land value is not the main objective of the Council which is primarily focussed on ensuring scheme deliverability. The conventional requirement in planning viability to meet the benchmark land value is not therefore in this instance a priority.
- 2.7 We set out below our conclusions regarding the different elements of the appraisal below:

Funding

- 2.8 The applicant has stated that £4.559m of direct funding will be required in order to ensure delivery of the scheme by covering the costs of development. We have been informed that this will be funded from borrowing and/or internal resources such as the Council's reserves.
- 2.9 The completed development will over time provide income from Social Rent units although this will not assist with the immediate funding of the development itself given that the Council does not intend to sell these units. It is therefore reasonable to assume that direct funding will be required.
- 2.10 The short-term cashflow over the development period will almost certainly show a deficit which would need to be covered by relatively long term funding arrangements. This is essential given that the Council plans to retain the affordable units and therefore will not benefit at the end of the development period from capital receipts from the sale of the affordable housing to a Registered Provider.

Cashflow model

- 2.11 We have not been provided with a copy of the applicant's cashflow model, although we have been informed that the applicant is now relying upon the latest residual valuation model as the key indicator of scheme viability, and we agree that this is a suitable model to use for the purposes of testing the level of affordable housing that the scheme can provide.

Affordable housing values

- 2.12 The applicant assumes it will receive Right to Buy income of £4.45m. Using typical valuation assumptions normally adopted by Registered Providers and Local Authorities, we estimate a value of £7.93m.
- 2.13 The applicant assumes that it will receive Right to Buy (RTB) receipts, based on 40% of the Social Rent units' occupants operating the Right to Buy.

Private market housing values

- 2.14 These are in line with local sales evidence, as we discuss further below.

Build costs

- 2.15 Our Quantity Surveyor, Neil Powling, has reviewed the cost information that has been provided by the applicant, and is satisfied with the level of detail provided in Walker Management's Cost Plan, which has allowed Neil to undertake a full benchmarking exercise by comparing the costs to Building Cost Information Service (BCIS) average tender prices. Neil has concluded that the costs are generally in line with BCIS rates, with the exception of the residential element of Block C and the retail space which both appear to be overstated, by £155,000 and £64,000 respectively.

3.0 BENCHMARK LAND VALUE

- 3.1 As stated above, the scheme shows a negative residual land value, therefore cannot viably support any additional affordable housing provision. This deficit in viability would increase further if a benchmark land value were to be applied.
- 3.2 The appraisal does include the relocation costs for the Dentists and Spectrum which we understand is a legitimate type of cost to apply in development appraisals of Council-led schemes.

4.0 AFFORDABLE HOUSING VALUES

- 4.1 The floor area of the Social Rent units totals 2,910 sqm (31,323 sqft), for which a capital value of £13.22m (£422 per sqft) has been inputted into the applicant's residual valuation. This value has been estimated by the applicant calculating 40% of these units' open market value i.e. how much they would realise if sold on the open market. We have been informed that the valuation assumes that Right to Buy 'one-for-one' receipts of £4.45m will be available to the Council.
- 4.2 We have been informed that the rents for affordable housing will be based on April 2015 target rents for Islington:
- 1-beds: £158-£160 per week
 - 2-beds: £173-£188 per week
 - 3-beds: £222-£248 per week
- 4.3 We have undertaken a summary appraisal of the affordable housing, using the above weekly rents. The gross rents total £374,000 per annum. We have undertaken a summary valuation by using the Council's applied Target Rents for each of the units and by applying the following assumptions:
- Management & Maintenance Costs: 15% of annual rent
 - Void Costs: 4% of annual rent
 - Major repairs: 1% of annual rent
 - Capitalisation rate: 6.0%
- 4.4 A capital value of £5.0m is generated by our valuation. Once Right to Buy receipts are factored in, this figure increases to £7.93m which suggests that the Council affordable housing values are somewhat overstated.

5.0 PRIVATE MARKET VALUES

- 5.1 The total value of the private market housing is £12.887m, which, based on the 1,074 sqm of total floorspace, gives a value of £11,999 per sqm (£1,114 per sqft). The private housing will comprise 5 one-beds and 11 two-beds. We have undertaken research into the local residential market in order to determine whether the values that have been applied in the appraisal are realistic.
- 5.2 The 16 private units are all located in Building A. This building will also include 19 affordable housing units together with a community centre and retail unit. The private housing will be situated on the 5th, 6th, 7th and 8th floors of Building A. The proximity to social housing may negatively impact on achievable private market values, as may the proximity to Old Street which is a relatively busy road.

- 5.3 There are 5 one-bed units valued at £730,000, and four 2-beds (3 person units) at £796,250. There are seven two-beds at £864,642 (these are the 2-bed, 4 person apartments). A 16th February 2015 Valuation Report by Deloitte provides a valuation of the private market housing. Whilst Deloitte has provided details of residential transactions for comparison purposes, little analysis and discussion of these is provided in relation to the proposed scheme.
- 5.4 We note the nearby King Square redevelopment where values were estimated by Deloitte at £1,027 per sqft. This rate is marginally lower than the Redbrick Estate scheme and may reflect the arguably poorer location of the King Square estate which is located on the busy City Road. Following a detailed analysis of the sales values, we concluded that the King Square scheme's estimated values were reasonable. Given the close similarities with the King Square scheme, we also conclude that the Redbrick Estate's values are realistic, and have confirmed this via further market research.

Analysis of sales evidence

The Eagle

The values cited at The Eagle development range from £997-£1,466 per sqft, most of which are units located on the 20th to 22nd floors which benefit from excellent views and will therefore sell at a premium to lower levels. A 2-bed on the 16th floor is available at £997 per sqft, and a 2-bed on the 18th floor at £1,019 per sqft.

The Eagle is due for completion in Autumn 2015 and therefore the figures reflect terms agreed on advance sales. These typically factor in a degree of price growth over the development period and may in consequence reflect values in excess of achievable present-day rates. Given the recent stall in house price growth and reduced levels of market activity this effect may be less marked than say 18 months ago.

- 5.5 The Eagle development is a 26 storey development which is in close proximity to Old Street roundabout. It is somewhat disadvantaged by its proximity to the busy City Road, but does benefit from an in-house private cinema for residents along with a gym and spa with pool, sauna and steam room. These additional features will add a premium to the unit prices and we would expect the units on offer at this scheme to command higher values than the units in the Redbrick Estate scheme.

Canaletto

- 5.6 The Canaletto scheme is highly comparable to Redbrick Estate in terms of location. This high rise development has similar communal facilities to The Eagle such as a cinema, gym and a swimming pool. It also has an exclusive club on the 24th floor which provides food and drink to residents and their guests. Given these features it is apparent that this development will achieve higher sales values than the proposed scheme, in particular the upper levels which will command premium values in respect of their views.
- 5.7 A 2-bedroom flat at £1,036 per sqft on the 9th floor and a 2-bed at £1,161 per sqft on the 11th floor are the most suitable of the Canaletto units for the purposes of comparison. We would not expect sales rates in the subject scheme to exceed these two Canaletto units which sold in late December 2014.

250 City Road

- 5.8 Like Canaletto, this scheme provides residents with additional facilities, including a gymnasium and swimming pool. We note however that, like the other developments examined, that this development is located on the busy City Road which may have a detrimental effect on sales values. Some of the recent asking prices for 250 City Road are as follows:

| | | | | |
|---------------------|------------|-------------|---------------------|------------|
| 250 City Road, EC1V | £1,650,000 | 136 (1,461) | £12,156 (£1,129) | 4th Floor |
| 250 City Road, EC1V | £935,000 | 66 (712) | £14,135 (£1,313) | |
| 250 City Road, EC1V | £840,000 | 63 (675) | £13,395 (£1,244) | 9th floor |
| 250 City Road, EC1V | £957,500 | 73 (787) | £13,096 (£1,217) | |
| 250 City Road, EC1V | £1,427,500 | 97 (1,043) | £14,732 (£1,369) | 25th Floor |

The Lexicon, 261 City Road

- 5.9 Located next to the Canaletto development, The Lexicon has all the features that are customary with modern high rise high specification developments such as resident's spa and gym. Although it has these additional selling points, it also is located on the busy City Road. Some of the recent asking prices for The Lexicon are as follows:

| | | | | |
|-------------------|------------|----------|---------------------|-------------------------------|
| The Lexicon, EC1V | £625,000 | 52 (559) | £12,042 (£1,118) | 7 th floor (1-bed) |
| The Lexicon, EC1V | £735,000 | 53 (570) | £13,868 (£1,289) | (1-bed) |
| The Lexicon, EC1V | £665,000 | 49 (532) | £13,455 (£1,250) | 7 th floor (1-bed) |
| The Lexicon, EC1V | £1,145,000 | 78 (843) | £14,623 (£1,358) | 26th Floor |
| The Lexicon, EC1V | £1,070,000 | 78 (843) | £13,665 (£1,269) | 23rd Floor |
| The Lexicon, EC1V | £1,175,000 | 82 (844) | £14,312 (£1,329) | 29th Floor |

- 5.10 We have analysed the sales values of each unit type below:

One-bedroom apartments

| Address | Asking Price | Size m ² (ft ²) | £ per m ² (ft ²) | Other |
|--------------------------|--------------|---|---|-----------------------|
| The Eagle, EC1V | £800,000 | 70 (751) | £11,466 (£1,065) | 5 th floor |
| 250 City Road, EC1V | £935,000 | 66 (712) | £14,135 (£1,313) | |
| 250 City Road, EC1V | £840,000 | 63 (675) | £13,395 (£1,244) | 9 th floor |
| The Lexicon, EC1V | £650,000 | 53 (568) | £12,311 (£1,144) | |
| Chronicle Tower, EC1V | £595,000 | 52 (563) | £11,376 (£1,057) | |
| The Lexicon, EC1V | £625,000 | 52 (559) | £12,042 (£1,118) | 7 th floor |
| The Lexicon, EC1V | £735,000 | 53 (570) | £13,868 (£1,289) | |

| | | | | |
|-------------------|----------|----------|------------------|-----------------------|
| The Lexicon, EC1V | £665,000 | 49 (532) | £13,455 (£1,250) | 7 th floor |
| The Eagle, EC1V | £678,000 | 58 (624) | £11,695 (£1,087) | 6 th floor |

Two-bedroom apartments

| Address | Asking Price | Size m ² (ft ²) | £ per m ² (ft ²) | Other |
|-----------------------|--------------|--|---|------------------------|
| Chronicle Tower, EC1V | £950,000 | 82 (882) | £11,594 (£1,077) | 9 th Floor |
| 250 City Road, EC1V | £957,500 | 73 (787) | £13,096 (£1,217) | |
| 250 City Road, EC1V | £1,427,500 | 97 (1,043) | £14,732 (£1,369) | 25 th Floor |
| The Eagle, EC1V | £1,150,000 | 83 (893) | £13,855 (£1,288) | 17 th Floor |
| Lexicon, EC1V | £1,145,000 | 78 (843) | £14,623 (£1,358) | 26 th Floor |
| Lexicon, EC1V | £1,070,000 | 78 (843) | £13,665 (£1,269) | 23 rd Floor |
| Lexicon, EC1V | £1,175,000 | 82 (844) | £14,312 (£1,329) | 29 th Floor |
| The Eagle, EC1V | £1,650,000 | 96 (1,033) | £17,188 (£1,597) | 25 th Floor |
| The Eagle, EC1V | £1,500,000 | 95 (1,023) | £15,789 (£1,466) | 24 th Floor |
| The Eagle, EC1V | £1,600,000 | 104 (1,119) | £15,385 (£1,430) | 23 rd Floor |
| The Eagle, EC1V | £1,500,000 | 95 (1,023) | £15,789 (£1,466) | 25 th Floor |

- 5.11 Many of these two-bed units are on the higher floors of the local developments and as such we would expect these tower units to command a premium over comparable units at a lower level. For example, looking at the units on offer in the Lexicon, it is clear to see the increase in unit values from the 23rd to the 26th floor. We therefore believe that the values applied in the appraisal for the two bedroom units are reasonable. Equally, these comparable schemes deliver higher levels of onsite facilities which have a substantial impact on achievable sales values.

Three-bedroom apartments

| Address | Asking Price | Size m ² (ft ²) | £ per m ² (ft ²) | Other |
|-----------------------------|--------------|--|---|------------|
| 250 City Road, EC1V | £1,650,000 | 136 (1,461) | £12,156 (£1,129) | 4th Floor |
| The Eagle, EC1V | £1,595,000 | 119 (1,281) | £13,403 (£1,245) | 22nd Floor |
| The Eagle, EC1V | £1,795,000 | 115 (1,238) | £15,609 (£1,450) | 24th Floor |
| 25-39 Seward Street, EC1V | £1,195,000 | 78 (841) | £15,321 (£1,421) | |
| Canaletto, City Road, EC1 | £1,825,000 | 110 (1,184) | £16,591 (£1,541) | |
| Eagle Point City Road, EC1V | £1,075,000 | 85 (915) | £12,646 (£1,175) | |

- 5.12 The asking prices for 3-beds at these comparable schemes are higher than the unit values applied in the appraisal, but this can be explained (as discussed above) by the fact that many of these units are on the upper floors of the developments and will benefit from higher levels of on-site facilities.

6.0 DEVELOPMENT COSTS

- 6.1 Our Quantity Surveyor, Neil Powling, has reviewed the cost information that has been provided by the applicant, and is satisfied with the level of detail provided in Walker Management's Cost Plan, which has allowed Neil to undertake a full benchmarking exercise by comparing the costs to Building Cost Information Service (BCIS) average tender prices. Neil has concluded that the cost are generally in line with BCIS rates, with the exception of the residential element of Block C and the retail space which both appear to be overstated, by £155,000 and £64,000 respectively.
- 6.2 The build cost estimate includes relocation costs of £300,000 for the Dentists and the Spectrum, which is in our view a realistic allowance.
- 6.3 Acquisition costs have been incorporated into the overall build costs. The total for Acquisition & Site Preparation is costed at £399,500, which we consider to be a reasonable estimate.
- 6.4 No finance costs are included in the residual valuation. The applicant has recently stated that it can borrow at 4.17%, which is Public Works Loan Board's borrowing rate. The scheme will start on site in April 2016 and complete in April 2018. Allowing for a typical pre-construction period of 6 months, we have calculated a total finance cost of £1.61m. If this finance cost were to be applied, it clearly would worsen the viability position of the scheme.
- 6.5 A Developer's Return is included at 17.5% on Cost for the private market housing and the commercial uses, while the affordable housing and community uses have a Return of 5% on Cost. We agree that these returns do not exceed typical levels of return that are adopted by private developers, who typically adopt a profit on cost of circa.25% for private housing, and 6-8% for affordable housing.
- 6.6 The Professional Fees of £2.9m reflect 18% as a proportion of the build cost of £16.3m. A rate of 18% is in excess of the more usual 10-12% typical benchmark rates applied in viability assessment. The professional fees have however been broken down and itemised and appear fully justified reflecting the circumstances of development of this scheme and are therefore accepted.
- 6.7 A Contingency rate of 5% is adopted, which is in line with typical benchmark rates.

BPS Chartered Surveyors

Appendix One:

Cost Review for Redbrick Estate application (P2015/0709/FUL) by Neil Powling FRICS

1 SUMMARY

- 1.1 Our adjusted benchmarking shows the residential elements of Block A and B to be reasonable but Block C to be high by £155,000 (£142/m²).
- 1.2 The estimate for the Retail space in Blocks A and B taken together is a little high by £64,000.
- 1.3 We consider the estimated costs of the Community Centre to be reasonable.

2 METHODOLOGY

- 2.1 The objective of the review of the construction cost element of the assessment of economic viability is to benchmark the applicant costs against RICS Building Cost Information Service (BCIS) average costs. We use BCIS costs for benchmarking because it is a national and independent database. Many companies prefer to benchmark against their own data which they often treat as confidential. Whilst this is understandable as an internal exercise, in our view it is insufficiently robust as a tool for assessing viability compared to benchmarking against BCIS.
- 2.2 BCIS average costs are provided at mean, median and upper quartile rates (as well as lowest, lower quartile and highest rates). We generally use mean or upper quartile for benchmarking depending on the quality of the scheme. BCIS also provide a location factor compared to a UK mean of 100; our benchmarking exercise adjusts for the location of the scheme. BCIS Average cost information is available on a default basis which includes all historic data with a weighting for the most recent, or for a selected maximum period ranging from 5 to 40 years. We generally consider both default and maximum 5 year average prices; the latter are more likely to reflect current regulations, specification, technology and market requirements.
- 2.3 BCIS average prices are also available on an overall £ per sqm and for new build work (but not for rehabilitation/ conversion) on an elemental £ per sqm basis. We generally consider both. A comparison of the applicants elemental costing compared to BCIS elemental benchmark costs provides a useful insight into any differences in cost. For example: planning and site location requirements may result in a higher than normal cost of external wall and window elements.
- 2.4 If the application scheme is for the conversion, rehabilitation or refurbishment of an existing building, greater difficulty results in checking that the costs are reasonable, and the benchmarking exercise must be undertaken with caution. The elemental split is not available from the BCIS database for rehabilitation work; the new build split may be used instead as a check for some, but certainly not all, elements. Works to existing buildings vary greatly from one building project to the next. Verification of costs is helped greatly if the cost plan is itemised in

reasonable detail thus describing the content and extent of works proposed.

- 2.5 BCIS costs are available on a quarterly basis - the most recent quarters use forecast figures, the older quarters are firm. If any estimates require adjustment on a time basis we use the BCIS all-in Tender Price Index (TPI).
- 2.6 BCIS average costs are available for different categories of buildings such as flats, houses, offices, shops, hotels, schools etc. The Applicant's cost plan should keep the estimates for different categories separate to assist more accurate benchmarking.
- 2.7 To undertake the benchmarking we require a cost plan prepared by the applicant; for preference in reasonable detail. Ideally the cost plan should be prepared in BCIS elements. We usually have to undertake some degree of analysis and rearrangement before the applicant's elemental costs can be compared to BCIS elemental benchmark figures. If a further level of detail is available showing the build-up to the elemental totals it facilitates the review of specification and cost allowances in determining adjustments to benchmark levels. An example might be fittings that show an allowance for kitchen fittings, bedroom wardrobes etc that is in excess of a normal benchmark allowance.
- 2.8 To assist in reviewing the estimate we require drawings and (if available) specifications. Also any other reports that may have a bearing on the costs. These are often listed as having been used in the preparation of the estimate. If not provided we frequently download additional material from the documents made available on the planning website.
- 2.9 BCIS average prices per sqm include overheads and profit (OHP) and preliminaries costs. BCIS elemental costs do not include these. Nor do elemental costs include for external services and external works costs. Demolitions and site preparation are excluded from all BCIS costs. We consider the Applicant's detailed cost plan to determine what, if any, abnormal and other costs can properly be considered as reasonable. We prepare an adjusted benchmark figure allowing for any costs which we consider can reasonably be taken into account before reaching a conclusion on the applicant's cost estimate.

3 GENERAL REVIEW

- 3.1 We have been provided with and relied upon a number of files and in particular:-
 - Valuation advice provided by Deloitte dated 16th February 2015
 - The Walker Management Estimate Summary dated 25th February 2015 in the total sum of £16,332,265
 - The Walker Management Estimate section breakdowns dated 25th February 2015
- 3.2 We have also downloaded a number of drawings from the planning website.
- 3.3 The Walker Management (WM) costs are provided in elemental detail with a breakdown for each functional category and block. Refer to our file "Elemental analysis and BCIS Benchmarking" - we have organised the information into a format to suit our benchmarking exercise.
- 3.4 The WM elemental totals have been grouped as opposed to following BCIS elemental format, although the section breakdowns do provide a level of elemental detail.

- 3.5 WM have priced preliminaries at 12.8% we consider this reasonable although a number of trades/ elements have additions for sub contract preliminaries with variously a 5% or 10% addition.
- 3.6 The Overheads and profit (OHP) have been priced at 4.5%. The contingencies have been priced at a combined rate of 5%. Both of these allowances we consider reasonable.
- 3.7 We have downloaded current BCIS data for benchmarking purposes including a location factor for Islington of 114; we have applied this factor in our calculations.
- 3.8 The combined total for site works, drainage, external services and site works outside the boundary is £2,351,530 (£369/m²). A reasonably detailed build-up of these works has been provided; the amount is high apparently reflecting the particular requirements and conditions of this site. External works are not included in BCIS average data therefore the full amount is treated by us as an abnormal cost in the adjusted benchmarking exercise.
- 3.9 We have used a default average for benchmarking the Community Centre; the maximum 5 year figure would be significantly more but it is based on a small sample size. The benchmarking adjusted for the external works apportioned to this section demonstrates that the estimated costs are well within benchmark.
- 3.10 We have used a shell only BCIS average for benchmarking the retail space. The adjusted benchmarking indicates that the estimate is high by £169/m² amounting to a total difference on the retail element of £64,000.
- 3.11 We have benchmarked the three residential blocks A, B & C separately: A is treated as a 6+ storey block; B and C as 3 to 5 storey blocks. The elemental data (unlike the average £/m² data) from the BCIS does not distinguish between storey heights. The WM estimates for each of the blocks A, B & C are £2,526/m², £2,549/m² and £2,716/m² respectively. It appears anomalous that C is at a higher rate than A when the reverse would be expected. In consequence the benchmarking shows Block A to be reasonable, Block B very slightly high but within a margin that is reasonable at this stage of the estimate. Block C is however high by £142/m² amounting to a difference of £155,000.

BPS Chartered Surveyors
Date: 2nd April 2015

ISLINGTON SE GIS Print Template

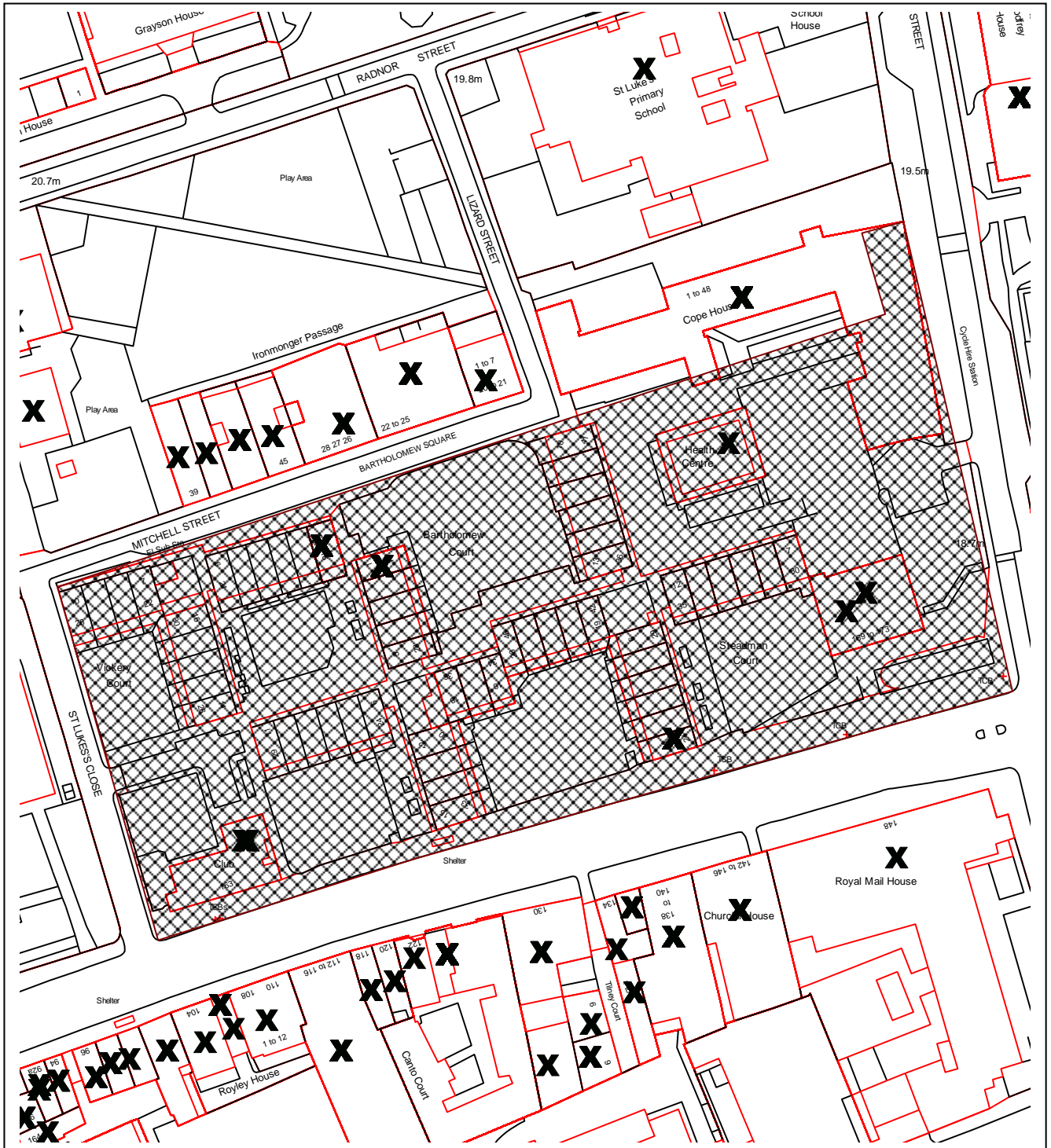

This material has been reproduced from Ordnance Survey digital map data with the permission of the controller of Her Majesty's Stationery Office, © Crown Copyright.
P2015/0709/FUL

This page is intentionally left blank